

Hydraulic Pick Up Header

OPERATORS AND PARTS MANUAL

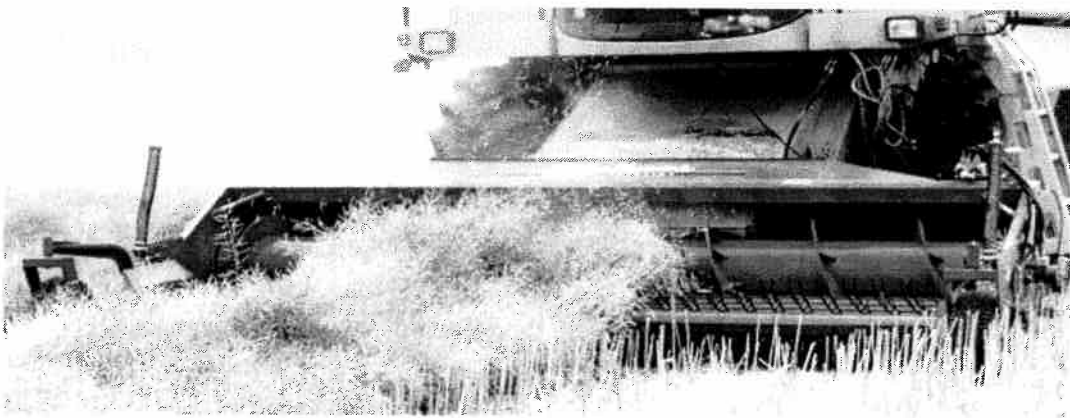

Shelbourne
REYNOLDS

Shelbourne Reynolds Engineering Ltd
Stanton
Bury St Edmunds
Suffolk IP31 2AR
England

Telephone: 01359 250415
Fax. No: 01359 250464

(Stores direct 01359 251231)
(Stores direct 01359 252031)



INVESTOR IN PEOPLE

ISSUE ..1
26.7.2002

OPERATORS MANUAL

CONTENTS

Section 1	INTRODUCTION
1.1	Foreword
1.2	Improvements and changes
1.3	Service Parts
1.4	Machine Identification
1.5	Warranty
Section 2	SAFETY PROCEDURES
2.1	Accident prevention
2.2	Before starting the machine
2.3	The machine in the field
2.4	Leaving the machine
2.5	Servicing the pick up header
2.6	Header attachment and detachment
Section 3	SPECIFICATION AND DESCRIPTION
Section 4	TRANSPORTATION
Section 5	PREPARATION FOR USE
5.1	Mounting the pick up header
5.2	Levelling the header
5.3	Angle of pick up header
5.4	Aligning header drive
5.5	Electro-hydraulic control box installation
5.6	Draper position settings
5.7	Draper skid settings
5.8	Setting the draper to the optimum angle
5.9	Stripper plate settings
5.10	Header skids
5.11	Header height indicator
5.12	Auger flight extensions
Section 6	FIELD OPERATION
6.1	Direction of travel
6.2	Header / draper height settings
6.3	Forward speed
6.4	Draper speed
6.5	Auger / finger position
6.6	Auger blockage / reversing
6.7	Picking up the swath
6.8	Adjustment/troubleshooting charts

Section 7

ADJUSTMENTS AND MAINTENANCE

- 7.1 Angle of pick up header
- 7.2 Aligning header drive
- 7.3 Draper position
- 7.4 Draper skid settings
- 7.5 Setting draper to optimum angle
- 7.6 Draper belt tensioning
- 7.7 Draper belt tracking
- 7.8 Changing draper belt
- 7.9 Changing draper plastic pick up tines
- 7.10 Stripper plate settings
- 7.11 Header skids
- 7.12 Auger position settings
- 7.13 Auger fingers
- 7.14 Auger stripper plates
- 7.15 Auger flight extensions
- 7.16 Hydraulic oil reservoir
- 7.17 Hydraulic filter
- 7.18 Hydraulic relief valves

Section 8

LUBRICATION

Section 9

MACHINE STORAGE

SECTION 1

INTRODUCTION

1.1 FOREWORD

This manual will assist the operator in setting the pick up header and combine combination to give optimum throughputs and loss levels in particular crops. It should be read carefully before putting the machine to work.

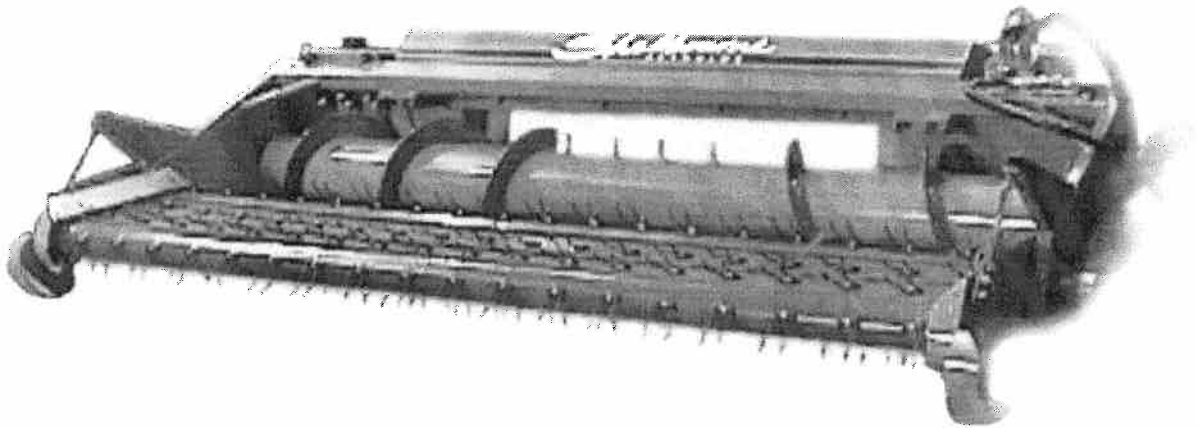

1.2 IMPROVEMENTS AND CHANGES

Shelbourne Reynolds Engineering are continually improving their products to meet the farmers needs and therefore reserve the right to make improvements and changes when practical to do so, without incurring any obligation to make changes and additions to equipment which has been sold previously.

1.3 **SERVICE PARTS**

Use guaranteed and genuine Shelbourne Reynolds Engineering service parts on Shelbourne Reynolds machinery to ensure maximum life and best performance. These are available through your Shelbourne Reynolds Engineering dealer.

When ordering service parts always quote the model, serial number and machine number.

1.4 **MACHINE IDENTIFICATION**

The serial and machine numbers of the pick up header are located on the right hand side sheet of the mainframe.

The machine number of the adaptor plate is located on the top right hand corner of the adaptor plate.

1.5 **SHELBOURNE REYNOLDS ENGINEERING LTD - WARRANTY TERMS AND CONDITIONS TO THE PURCHASER**

GENERAL

1. This warranty will become available to you when you have paid for the equipment and returned, duly completed, the delivery and warranty registration forms. It will expire on the anniversary of purchase from the dealer. After that date Shelbourne Reynolds will have no further liability under this warranty to you except in respect of claims already notified. This warranty is not transferable and is available only to the original purchaser from our dealer. In the case of purchasers having leasing or similar arrangements the first user shall be deemed the original purchaser and you shall be deemed to have paid for the equipment.

USE AND MAINTENANCE

2. To maintain the benefit of the warranty throughout the twelve month period you must have the machine serviced in accordance with our recommendations and use the machine properly. If on inspection the machine appears to have been either misused, overloaded, improperly operated, neglected, not properly maintained, altered or repaired without our consent this will invalidate the warranty. We shall have no further liability under it to you at all. (If you require any guidance as to use you should contact the dealer.)
3. Our liability under this warranty is dependent upon your making the equipment and facilities available, for inspection and testing.
4. In this warranty the expression, "defective product" means any part of the equipment you have purchased which shows evidence of a defect in the materials, design (due regard being given for the state of the art at the time we designed it) or Shelbourne Reynolds' workmanship. Wearing parts, such as belting, are excluded.

Parts not manufactured by Shelbourne Reynolds, for example tyres and alternators, are also excluded.

OUR OBLIGATIONS

- 5. If you discover a defective product you should contact the dealer from whom your machine was purchased. The dealer will notify us of your claim. Our obligation will then be to either replace, or if we consider it appropriate, repair the defective product. Alternatively, we may arrange for our dealer to carry out this work. YOU MUST NOTIFY THE DEALER OF THE DEFECT WITHIN SEVEN DAYS OF THE DAY ON WHICH IT IS DISCOVERED AND YOU MUST NOT USE THE EQUIPMENT AFTER DISCOVERY. FAILURE TO OBSERVE EITHER OF THESE OBLIGATIONS WILL INVALIDATE THE WARRANTY AS IS APPLIES TO THAT DEFECT. Any defective products replaced must be returned to SRE for inspection.

NO ADMISSION

- 6. On occasions we may, to preserve goodwill, replace parts even though they are not in our opinion defective. Accordingly, our agreeing to repair or replace a part cannot in any circumstance be deemed an admission that it was defective.

LIMITATIONS

- 7. This warranty shall not apply to products made up in accordance with customer originated designs.
- 8. No warranty, condition or other term implied by statute or common law as to the merchantability or fitness for a particular purpose, is intended or given by this warranty. All such warranties which may apply between Shelbourne Reynolds and yourself are excluded to the fullest extent permitted by law.
- 9. In any case, except in respect of death or personal injury caused by our negligence, we shall not be liable to you by reason of any representation or implied warranty, condition or other term, or any duty at, law or under the express terms of any contract, for the consequential loss or damage (whether for loss or profit or otherwise and including delay in harvesting, loss of crops, expense incurred for labour, additional or substitute material, rental whatsoever and whether caused by our negligence, the negligence or our employees or agents or otherwise) which arises out of or in connection with the use of the goods by you.
- 10. Time of repair is not of the essence.
- 11. No person or persons are authorised to alter, modify or enlarge this warranty on behalf of Shelbourne Reynolds.
- 12. Shelbourne Reynolds shall not be liable for any failure to comply with any part of the warranty where such failure is due to circumstances beyond their reasonable control, including difficulty in obtaining materials or replacement parts.

CALL OUT CHARGES

- 13. Shelbourne Reynolds and all dealers reserve the right to make a reasonable charge for call outs made at your request which do not turn out to relate to defective products.

YOUR STATUTORY RIGHTS ARE UNAFFECTED.

SECTION 2

SAFETY PROCEDURES

2.1 ACCIDENT PREVENTION

Accident programmes can only prevent accidents with the co-operation of the persons responsible for the operation of the equipment.

For safety of yourself and others, operate equipment with care and do not take unnecessary risks which could cause an accident.

The combine manufacturers operators manual safety precautions should be adhered to along with the following additional safety precautions listed when using a pick up header

CAUTION



In addition to the following list, this symbol will appear throughout this manual whenever your safety is involved.

PRECAUTIONS

2.2 BEFORE STARTING THE MACHINE

1. Read the manual thoroughly.
2. Check that all guards are properly secured.
3. Ensure that no person is working on or inside the machine.
4. Check that all observers are clear of the machine. Warn bystanders by sounding the horn several times.

2.3 THE MACHINE IN THE FIELD

5. Do not permit anyone other than the operator to ride on the combine.
6. Always stop the engine and apply handbrake before removing or opening any guards or clearing a blockage.
7. Do not go under the pick up header unless it is securely blocked or the header safety latch is lowered onto the lifting cylinder
8. NEVER go in front of the machine whilst the header is running.
9. Always replace all guards after making any adjustments or lubricating the machine. Replace or repair any damaged or missing guards immediately.
10. Do not work around the machine in loose clothing that might get caught in moving parts.
11. Keep hands away from moving parts.
12. Keep children away from and off the machine at all times.

2.4 LEAVING THE MACHINE

13. Park the machine on reasonably level ground.
14. Apply the parking brake.
15. Lower the header to the ground.
16. Stop the engine and remove ignition key.

2.5 SERVICING THE PICK UP HEADER

17. Ensure that the header is on the ground or if in the raised position, that it is securely blocked or the header safety latch is lowered onto the lifting cylinder.
18. Stop engine and apply handbrake before performing any adjustments or lubrication and before opening or removing any guard.
19. Always re-install all safety guards on completion of servicing.

2.6 HEADER ATTACHMENT AND DETACHMENT

20. Follow the procedure described in the combine operators manual for header attachment and detachment.

SECTION 3

SPECIFICATION & DESCRIPTION

RIGHT AND LEFT HAND OF THE MACHINE AS TERMED IN THE MANUAL IS AS VIEWED WHEN IN THE DRIVERS SEAT.

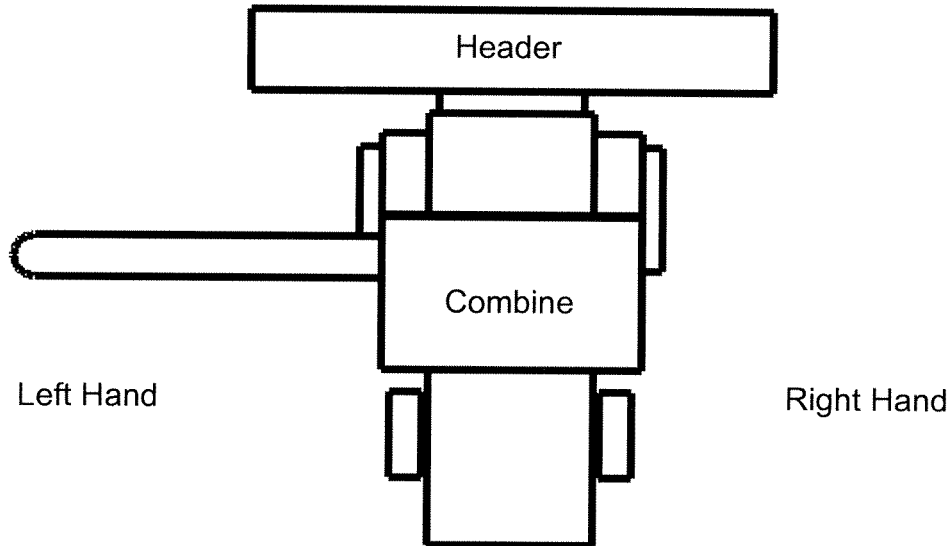

ALL MACHINES

- Multi-plate - Interchangeable adaptor plates and drive kits for mounting pick up header to other popular combine types.
- Auger - Direct hydraulic drive with a fixed speed of approximately 180 r.p.m. Diameter 504mm over flights with adjustable retractable fingers and stripping plates, and bolt on 90 degree flight extensions to allow for width variations in combine feed elevators
- Draper - Direct hydraulic drive with a variable speed conveyor range between 0 to 390 r.p.m. (approx).
One piece, joined draper belt constructed out of a low maintenance PVC, fitted with flights and plastic tines.
Belt tensioning and tracking done from sides of draper. Skids and canvas edged stripper plate fitted.
- Hydraulic - Header electronic control box positioned in cab of controls combine to give operator control of auger reverse facility and draper speed. The pick up headers unique hydraulic auger reverser can be activated without shutting down the combine drives.
- Adjustable skids - Mounted under header mainframe to control ground height.
- Crop slide kit - Optional extras.

TECHNICAL SPECIFICATIONS:

Sizes and weight are as follows:-

	Pick up Header
a	2050mm
b	1200mm
c	3700mm
d	3200mm
e	1500mm
e	900kg approx.

a= Draper in field position.
e= Draper in raised position.

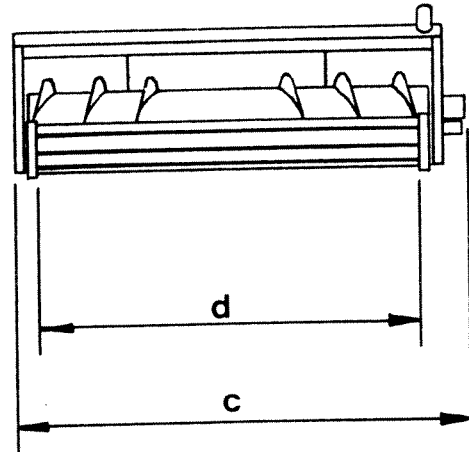
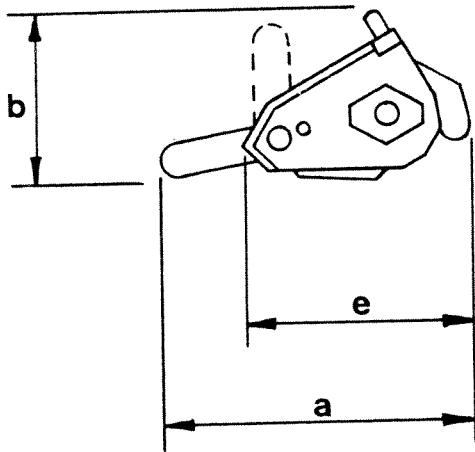

SECTION 4

TRANSPORTATION

To prevent damage to the pick up header, the machine should be moved only by one of the following methods:

- Attaching to combine
- By slinging the mainframe using the two designated sling points for overhead lifting.
- On a trailer which gives suitable support in the correct positions of the header and provides adequate stability.

DO NOT

- Attempt to lift under the header with a fork lift, unless the header is on an adequately supportive pallet.
- Remove header onto floor without placing secure blocks under the front corners of the machine.

SECTION 5

PREPARATION FOR USE



Read this section carefully and carry out settings listed before field use. If in any doubt of adjusting the following, consult your dealer.

5.1 MOUNTING THE PICK UP HEADER.

The header mounts onto the combine in the same manner as the normal cutting platform. Refer to combine operators books for fitting details.

5.2 LEVELLING THE HEADER

The header should be parallel with the front axle of the combine, if it is not, then it should be adjusted according to the combine operators manual, as adjustment method is the same as that for the conventional cutterbar.

5.3 ANGLE OF PICK UP HEADER

The angle of the pick up header is adjustable. This allows the header to be tipped forwards or backwards on the adaptor plate. This enables the front, flat area of the auger pan to be set level or slightly slopping down to the auger trough, when the header is in the harvesting height position. See pick up header adjustments and maintenance section.

5.4 ALIGNING HEADER DRIVE

See pick up header adjustments and maintenance section.

5.5 ELECTRO-HYDRAULIC CONTROL BOX INSTALLATION.

The electro-hydraulic control box needs to be situated inside the cab and the feed cable connected to a 12V supply either by wiring into the ignition or an auxiliary outlet. (IMPORTANT - Do not connect the feed cable to a 24V circuit unless a voltage reducer is used) The header cables with connector should be routed down the L.H. side of the feed elevator and secured in suitable places. This lead can then be connected to the lead coming from the valve control block by use of the 6-way male/female coupling.

(For certain combine models with electronically activated header reverser systems, an additional wire can be connected from the header control box. This would allow the header to reverse automatically along with the combine elevator. Consult Shelbourne Reynolds if required).

5.6 **DRAPER POSITION SETTINGS.**

The draper can be set in two different positions within the mainframe depending upon the crop type being harvested. For crops which are bulky (i.e. winter and spring oil seed rape) use the front position. The rear position would therefore be used for crops of less bulk (i.e. clover, grass etc.)
See pick up header adjustment and maintenance section.

5.7 **DRAPER SKID SETTINGS**

On both the front corners of the draper frame adjustable skids are fitted. These are to restrict the fingers from touching the ground when harvesting. They should initially be set so that when the skids touch, the fingers are approximately 50mm (2") above the ground.
See pick up header adjustment and maintenance section.

5.8 **SETTING THE DRAPER TO THE OPTIMUM ANGLE**

The draper assembly pivots around the drive roller within the pick up header mainframe. This therefore allows the draper to have a variable angle to the ground. For the least swath disturbance this angle needs to be as acute as possible.
See pick up header adjustment and maintenance section.

5.9 **STRIPPER PLATE SETTING**

The stripper plate can be set in two positions of which generally it will be used in the most forward. This also has an adjustable canvas and steel edging strip. Its purpose is to wipe the pick up fingers clean of crop and at the same time retain any loose seed.
To adjust see pick up header adjustment and maintenance section.

5.10 **HEADER SKIDS**

Underneath the header mainframe two adjustable skids are fitted. In operation the header will normally be carried, but it could on occasion touch the ground. The skids will protect the bottom of the mainframe and assist the operator. Initially the skids can be set in a mid-position.
See pick up header adjustment and maintenance section.

5.11 **HEADER HEIGHT INDICATOR**

This should be set as described in the combine operators manual.

5.12 **AUGER FLIGHT EXTENSIONS**

The inner ends of the auger flight have removable extensions. These can be unbolted to increase the width of feed from the auger into the combine feed elevator.
See pick up header adjustment and maintenance section.

SECTION 6

FIELD OPERATION

OPERATING THE PICK UP HEADER.



Read this manual carefully before operating the pick up header in the field. To get optimum performance from your Shelbourne Reynolds pick up header the operator should keep to the following procedures of operation. The main objective is to lift the swath off the stubble and feed it to the combine with the least disturbance possible, several factors can affect this.

6.1 **DIRECTION OF TRAVEL.**

The direction of travel is important when picking up the swath. To obtain the best crop movement on to the draper the combine should travel in the same direction as the swather. Travelling the opposite direction has a tendency of excessive crop disturbance which will effect the efficiency of the machine.

6.2 **HEADER / DRAPER HEIGHT SETTINGS.**

The height of the header is adjusted from the combine cab by the operator using the header height hydraulic adjusting lever or switch.

Generally the header height needs to be as low as possible to the crop, but not too low so that the skids are grounding constantly. This will therefore allow the draper to be set to a shallow angle.

Once the draper optimum angle has been set then the header height will also control that of the draper.

Obviously draper height needs to be just low enough to recover the crop. When in operation the draper skids should be clear of the ground most of the time allowing the support chains to be taught

6.3 **FORWARD SPEED.**

This is dependant upon size and capacity of the combine being used. The maximum speed will be governed either by the amount of acceptable combine loss levels or a facility which is overloaded. To maximise efficiency the fastest forward speed possible should be used.

6.4 **DRAPER SPEED.**

This needs to be directly related to the ground speed. In operation the swath being lifted and transported by the draper needs the least disturbance possible. By this the draper linear belt speed needs to be equal or very slightly faster than ground speed. The speed is adjusted from the control box within the cab and will need adjusting every time the forward speed is varied.

6.5 AUGER / FINGER POSITION SETTINGS.

The auger is mounted into the mainframe by the use of bolt in plates which are then adjustable in both the vertical and horizontal position. In field operation, the auger could possibly require adjusting to suit a condition.

The position of the auger finger retraction is also adjustable. This is factory set to a standard position.

See pick up header adjustment and maintenance section.

6.6 AUGER BLOCKAGE / REVERSING.

If at any time the auger gets blocked and stalls during operation, the hydraulic control system has a reversing feature built into it. If this occurs firstly stop all forward movement of the combine immediately, then simply press and hold the auger reverser button mounted on the electro-hydraulic control box in the cab.

With this the draper will stop moving and the auger will run in the reverse direction. Hold the button down for a few seconds or until the blockage is freed.

At this stage release the reverser button. With this the auger will automatically change direction to run in the normal manner where as the draper will delay for approximately 2-3 seconds before re-starting. This will allow the auger to clear itself before any more crop is fed from the draper.

If the auger blocks again repeat reversing procedure again.



If for some other reason it still blocks, totally shut down the combine, lower the header to the ground and investigate blockage.

6.7 PICKING UP THE SWATH.

Follow in order the following procedure and checks to set the pick up header -

1. Ensure that all previous preparations have been carried out.
2. Begin to pick up the swath keeping a close watch on crop movement in the header. Set speeds to keep crop flow smooth and undisturbed.
3. When at a convenient stage stop machine and inspect area where swath had laid.
4. Any alterations to settings should be made with reference to adjustment charts on the following pages.
5. Continue harvesting but once again check for improvement.

ADJUSTMENT CHARTS

PROBLEM	CAUSE	REMEDY
CROP LOSS AT FRONT OF DRAPER		
Heads shattering or breaking off	Draper speed too fast for ground speed	Decrease draper speed. see section 6.4
	Draper speed too slow for ground speed.	Increase draper speed. see section 6.4
	Draper and header height too high.	Lower draper and header height. see section 6.2
	Direction of travel incorrect.	Change direction of travel. see section 6.1
	Draper angle too great	Lessen draper angle. see section 7.5
Seeds rolling off front of draper.	Damaged conveyor flights.	Replace draper belt. see section 7.8
CROP LOSS AT REAR OF DRAPER		
Crop being pulled forwards under draper	Stripper plate not set correctly.	Re-set stripper plate see section 7.10
	Auger not clearing crop satisfactorily	Set auger fingers. see section 7.13
		Set auger position. see section 7.12
Loose seed falling in front of stripper plate	Stripper plate not set forward.	Set stripper plate forward. see section 7.10
	Stripper plate spring retainers broken or set incorrectly.	Set or replace. see section 7.10
	Header frame angle not set in correct position.	Set angle. see section 7.1

PROBLEM	CAUSE	REMEDY
IRREGULAR FEEDING THROUGH HEADER.		
Crop not moving smoothly on draper	Pick up tines broken or damaged.	Replace see section 7.9
	Draper speed to ground speed incorrectly set.	Adjust speed from control box.
Draper loosing speed	Draper jammed	Clear object
	Draper belt slipping	Tension draper belt see section 7.6
	Hydraulic relief valve set incorrectly	Check draper relief valve pressure setting. see section 7.17
	Auger speed reducing.	Check main relief valve pressure setting see section 7.17
	Hydraulic component failure.	Contact SRE dealer.
	Electrical control box failure.	Check fuse and power supply. see section 5.5
Irregular flow between draper and auger	Draper position in main frame incorrect.	Contact SRE dealer Set position for crop type. see section 5.6/7.3
	Auger set too low	Adjust auger height. see section 7.12
	Draper angle too great	Lessen draper angle. see section 7.5
Auger speed reducing	Auger overloaded.	Reduce forward speed
	Auger set too low.	Adjust auger height. see section 7.12
	Main relief valve set incorrectly.	Check main relief valve pressure setting. see section 7.17
	Hydraulic component failure.	Contact SRE dealer

PROBLEM	CAUSE	REMEDY
MECHANICAL PROBLEMS		
Draper always runs to one side.	Contamination inside draper.	Clear contamination.
	Belt tension incorrect	Set tension. see section 7.6
	Rollers not parallel.	Adjust accordingly. see section 7.6/7.7
	Draper support chain lengths require adjustment.	Adjust lengths to track the belt. see section 7.7
HYDRAULIC/ELECTRICAL PROBLEMS		
Main relief valve recommended setting cannot be achieved.	Combine drive slippage.	Adjust according to combine manual.
	Hydraulic oil level low.	Check oil level. see section 7.15
	Hydraulic pump failure.	Test hydraulic circuit. Contact SRE dealer.
Header will not reverse when red button is pushed.	No power to electric control box.	Check power supply and fuse. see section 5.5
	Plug to header from control box not connected, or faulty.	Connect/check the plug.
	Electrical control box or connection failure.	Contact SRE dealer.
	Hydraulic valve failure	Contact SRE dealer.
Draper will not restart after reversing auger,	Delay feature set incorrectly.	Check delay time of 2 to 3 seconds. For adjustment contact SRE dealer.
	Electrical control failure.	Contact SRE dealer.
	Hydraulic valve or component failure.	Contact SRE dealer.

PROBLEM	CAUSE	REMEDY
Hydraulic services lacking power.	Oil over heating	Check oil level. see section 7.15
	Filter blocked.	Change oil filter. see section 7.16

SECTION 7 PICK UP HEADER ADJUSTMENTS AND MAINTENANCE

7.1 ANGLE OF PICK UP HEADER.

The angle of the pick up header is adjustable. The bolt in adaptor plate attaching the pick up header to your combine has two fixing studs (A) Fig.1 located just under the top beam near the centre opening. These fixing studs are adjustable and will therefore adjust the angle of the pick up header.

FIG 1.

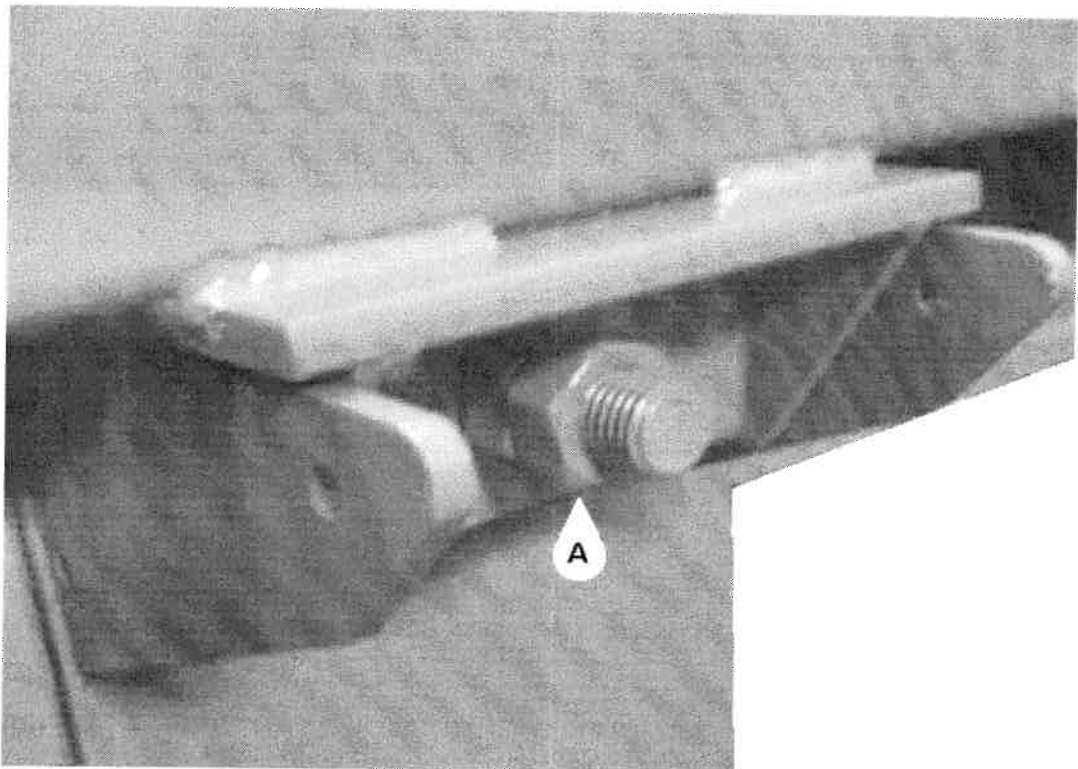

To correctly set :-

1. If your machine is fitted with a solid drive input, i.e. not a pto shaft, then DISCONNECT the drive coupling.
2. Set the pick up header skids in a mid-position.
3. On the level concrete lower the pick up header to the ground i.e. so the skids touch the concrete.
4. At this stage the flat front section of the auger pan should be horizontal or slightly sloping back to the auger trough.
5. If adjustment is required, before adjusting the studs, the bolts securing the auger stripper plates on the adaptor plate only should be loosened to prevent jamming.

6. Adjust the studs (A) Fig.1. of the adaptor plate equal amounts until the setting is approximately correct.
7. Lock the adjusting stud nuts.
8. Re-set the auger stripper plates to give approx. 5mm clearance from the auger flights.
9. For machines fitted with the solid drive on the pick up header main frame, realign the header drive.

NOTE:- When making this adjustment the auger to feed elevator clearance will also change. Before operating the machine, check that the auger and feed elevator do not hit each other, re-adjust the auger, or elevator if necessary.

7.2 ALIGNING HEADER DRIVE

The pick up header being of narrow width has a compact input drive system connecting directly onto a hydraulic pump and gearbox. Depending on combine models, the pump and gearbox maybe;

(a) mounted to the rear of the header and connected to combine header drive via a PTO shaft. With this system there are 3 possible mounting positions. The position which leaves a PTO angle of no more than 20 degrees should be used, refer to MAN-0311 for details



Keep all PTO guards in place when operating. Do not hang the shaft from the guard chain, use the support hook provided. If a short PTO is supplied and cannot be supported by the hook the PTO shaft should be removed.

(b) directly mounted onto the combine header drive shaft. When the pump and gearbox are mounted directly to the combine a system of a male/female drive coupling and torque arms are used. These torque arm lengths are simply adjusted to ensure assembly clears hoses and brackets.



For drive arrangements that use 2 torque arms (Case IH) the lateral float system must not be used. Tilting the header could cause damage to the combine header drive shaft. If possible disable lateral float circuit.

(c) directly mounted onto header using a sliding solid drive arrangement.

Due to no mis-alignment allowable on the solid drive shaft the hydraulic pump and gearbox are mounted to the header by the use of fully adjustable brackets. This brackets along with any drive support will need proper alignment before usage.

DRAPER

7.3 DRAPER POSITION.

As previously mentioned the draper can be set in two different positions. The following procedure should be used to change position ;

1. Remove draper drive motor, by simply removing mounting plate fixing bolt and then withdrawing motor and plate assembly from drive roller.
2. Support draper assembly with blocks or similar
3. Loosen and remove the fasteners that hold the draper bearing supports on to both ends of the mainframe side sheets. Withdraw the bearing supports from the mainframe allowing the draper to be released.
4. Remove the cover plates fitted to the second position.
5. Align the draper drive roller with this different position and insert bearing supports. Secure with fasteners.
6. Fit draper drive motor in new position.
7. Replace cover plates to position now not used.

7.4 DRAPER SKID SETTINGS.

The draper skids fitted to the front corners of the draper frame can easily be adjusted to various heights. SEE FIG.2.

They should be set to give a minimum distance of 50mm (2") from pick up tine tip to the ground when the skid is on the ground.

To adjust (see fig 2) -

1. With the machine on level concrete lower the header fully so that the skids touch the ground and the support chains are slack.
2. Check distance of pick up tine tip to ground level.



Support draper with something at this stage.

3. Loosen the three fasteners (A) slightly on both ends of draper.
4. Using the slot in the skid adjuster bar (B), move the skid to the height required.
5. Tighten fasteners.(A)

7.5 SETTING DRAPER TO OPTIMUM ANGLE.

The draper angle can be adjusted by increasing or decreasing the length of the support chains (C).

Coarse adjustment is obtained by varying chain links and fine is given from the adjustable links.

To set angle (see fig 2):-

1. Ensure that the header skids are in a mid-position.
2. On level concrete lower the header so that the header skids are touching the ground.

FIG 2

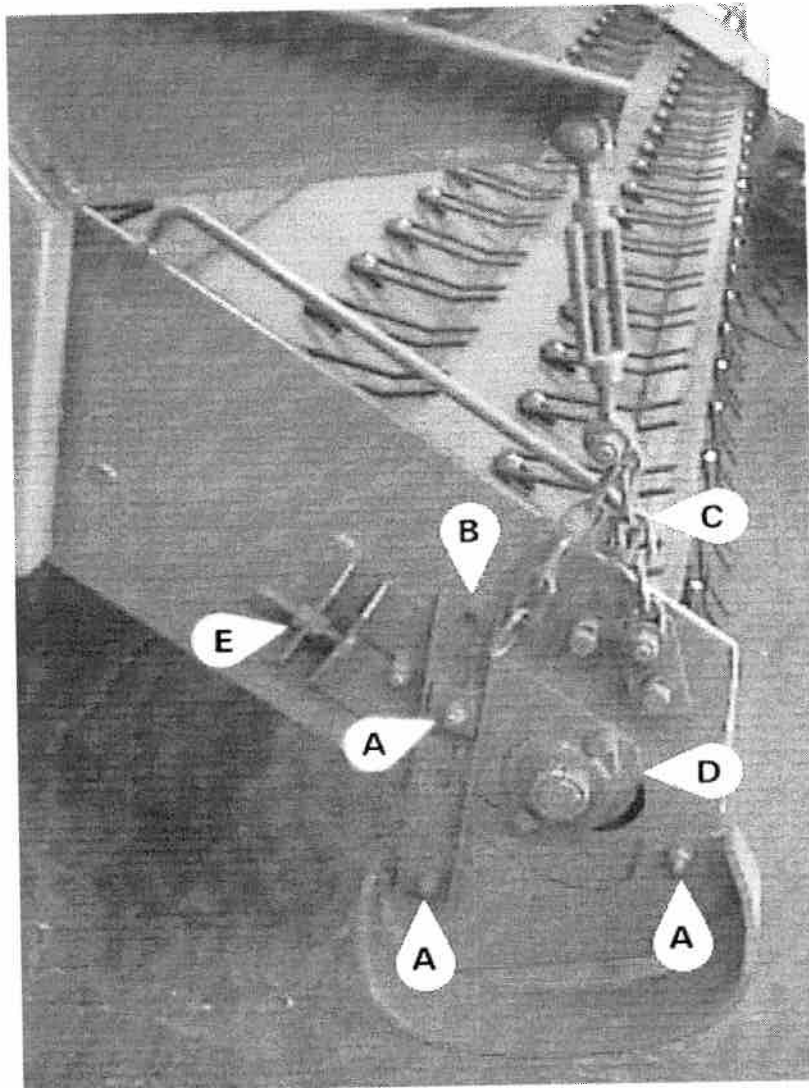

3. Now adjust the support chain assemblies (C) so that both the draper skids touch the ground.

IMPORTANT - Adjusting the angle of the draper will also adjust the tracking of the belt if both support chains are not correctly set.
See draper belt tracking (section 7.7).

7.6 DRAPER BELT TENSIONING.

The conveyor belt is tensioned by adjusting the position of the idle roller within the draper frame. SEE FIG 2. Tension is applied by loosening all fasteners holding adjusting plate (D) to the draper frame and then adjusting the position of the nuts on the studding (E). When the belt is tensioned correctly it should experience 0.3 - 0.4 % elongation. By this if the belt in the relaxed untensioned state is marked in two places exactly 0.5 metre apart. Then when tensioned the marks should be 501 - 502mm apart.

Ensure that both ends of the belt are tensioned to the same amount.

7.7 DRAPER BELT TRACKING.

Belt tracking is controlled by three factors on the pick up header ; (SEE FIG 2)

1. Tensioning devices on both ends of idle roller (D & E).
Ensure that the idle roller when in correct tension is parallel to the drive roller.
2. Lengths of support chain assemblies (C).
Ensure that the support chain assemblies are initially identical in length. Run the header in a raised position so that the draper support chain assemblies are taught. If the belt moves to one side and is forced onto the roller disc, track the belt to the centre by slightly shorten the length of that side support chain assembly. Allow the belt time to re-track and adjust again if necessary.
This principal will mean that when picking up a swath if only one draper skid happens to ground the belt will adjust its tracking. When that skid then clears the ground and the support chain goes taught the belt will re-track to the middle again.
3. Crowned drive roller.
This means that the belt is always influenced to track to the centre by using a crowned drive roller. The roller has tapered end sections leaving a parallel middle portion.
This feature is not adjustable by the operator.

7.8 CHANGING DRAPER BELT.

If at some time it is required to remove or replace the draper belt use the following procedure ;

1. Remove the draper drive motor by removing the mounting plate fixing bolt, then withdraw motor and plate assembly from the drive roller.
2. Support draper assembly with blocks or similar
3. Remove the draper support chain assemblies.
4. Loosen and remove the fasteners that hold the draper bearing supports on to both ends of the mainframe side sheets. Withdraw the bearing supports, allowing the complete draper assembly to be separated from the mainframe.
5. Remove draper belt tension using opposite procedure as previously described in section 7.6

6. Remove the stripper plate as described in section 7.10.
 - 7.. From one end of the draper only, remove ;
 - (a) the idle roller bearing locking ring
 - (b) the drive roller snap ring
 - (c) the fasteners that secure the torsion frame to the draper side sheet.
 8. This will allow the draper side sheet to be withdrawn from the rollers. The belt can then be removed.
- IMPORTANT** - Ensure that the pick up tines are previously fitted to the replacement belt prior to reassembly.
9. Install new belt onto rollers and reassemble in reverse order of the above, ensuring correct orientation of tines.
 10. Tension and track the belt as described in sections 7.6 & 7.7.

7.9 CHANGING DRAPER PLASTIC PICK UP TINES

If a plastic draper finger is damaged or needs replacing ensure that the removal is carried out when the tine is positioned on one of the rollers. The reason for this is that the finger is simply secured to the belt by means of a large flat headed bolt. If a finger is removed between rollers the bolt will fall into the draper and cannot easily be re-positioned. Ensure that when fitting fingers the square shank on the bolt engages into the square hole on the finger.

7.10 STRIPPER PLATE SETTINGS.



Fully raise header and engage safety latch.

The stripper plate is mounted to the rear of the draper side sheets. It is attached by using machined pins set into key hole shaped slots. The back of the stripper plate is forced down onto the auger pan by five spring plates.

To move the position of the stripper plate ;

1. Firstly remove the spring plates.
2. Using the threaded system on the machined pins narrow the width of the stripper plate fixings. Then lift one end of the stripper plate so that the machined pin rides up the keyhole to the large hole. Pull that end clear of the draper frame and then remove second end from keyhole.
3. Re-fit stripper into different position using reverse procedure.
4. Re-fit the spring plates

NOTE - The spring plates have two sets of fixing holes. These would be used when the draper position is moved to the rear setting.

On to the stripper plate is bolted a canvas edging strip. This strip has slots punched into it so that it can be moved closer to the fingers when it gets worn.

7.11 HEADER SKIDS.

Both header skids are secured to the mainframe by fasteners through slotted holes. This will allow the skids to be adjustable in height.

Ensure both skids are set to the same setting.



When setting skids always have header in the fully raised position and engage lift cylinder safety latch's.

7.12 AUGER POSITION SETTING

The auger position is set at the factory. This pre-set position should be suitable for most crops and conditions, however, if the position needs to be altered the auger can be adjusted by the studding (A) for up or down and (B) fore or aft. SEE FIG 3.

Slacken all stripper plate securing bolts if auger is moved back.

1. To move up or down, slacken off the auger support plate locking bolts (C) and adjust stud (A) as indicated. Adjust both ends of the auger to equal amounts.
2. For fore and aft movements, slacken off the auger support plate locking bolt and adjust stud (B) as indicated. Again adjust both sides of the auger equal amounts.
3. Tighten bolts (C) and locknuts when adjustment is complete.
4. Reset auger stripper plates.

IMPORTANT.

After adjusting the auger, it should be rotated by hand to ensure that nothing on the auger fouls.

FIG 3.

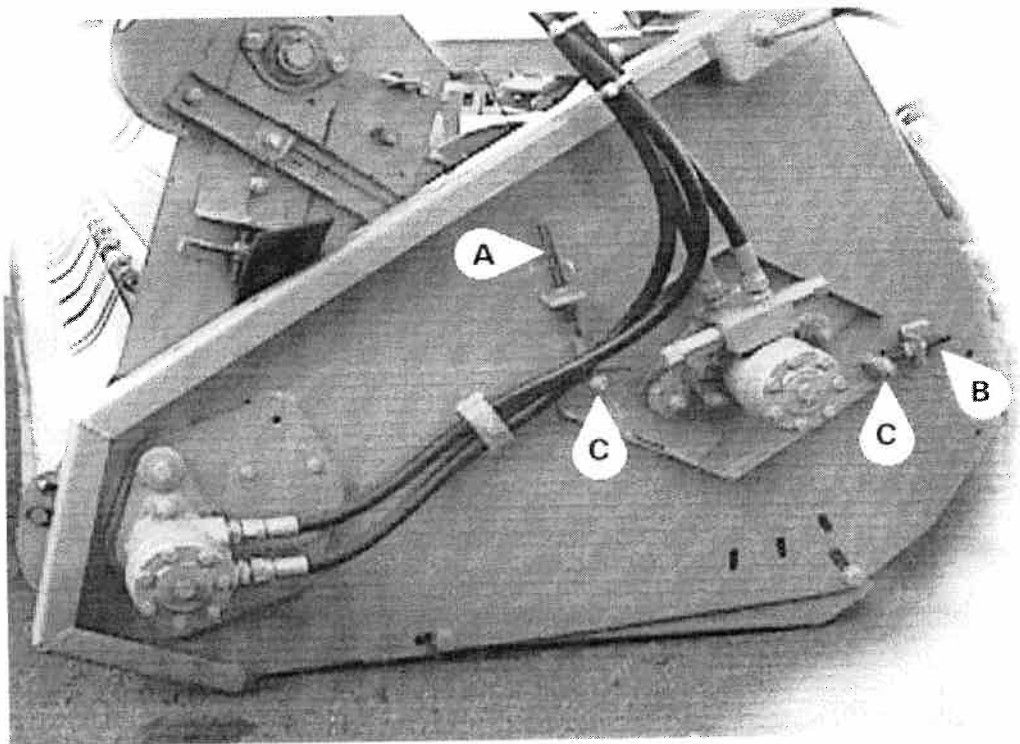

7.13 **AUGER FINGERS**

The position of the auger finger retraction is pre-set at the factory. It is adjusted by moving the handle situated on the right hand side of the mainframe. To adjust it, slackening off the bolt on the handle and move the handle to the required position.

7.14 **AUGER STRIPPER PLATES**

The stripper plates (B) are behind the auger across the width of the machine, except for the centre opening (SEE FIG 4). These should be set approximately 5mm from the auger flight. They are adjusted by slackening all the bolts (A) on the stripper plate and moving it on the slots before re-tightening. The stripper plate or the adaptor plate is adjusted independently to the same clearance.

7.15 **AUGER FLIGHT EXTENSIONS**

For combines with wide feed elevators the 90 degree flight extensions should be removed. The fasteners that fix the extensions to the auger should be replaced, once the flight extensions have been removed, to cover the fixing holes.

FIG 4.

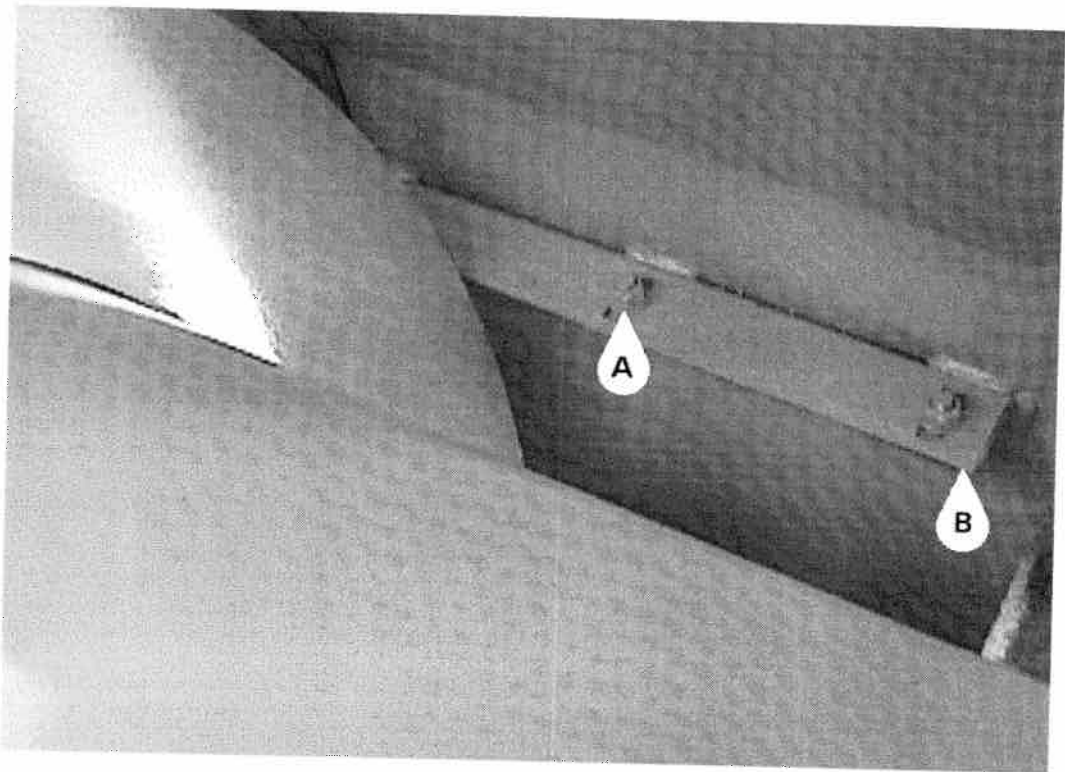

7.16 HYDRAULIC OIL RESERVOIR.

The hydraulic oil RESERVOIR is designed in such a manner that an external tank is connected to the header top and bottom beams. The oil capacity is made up by part of the tank and the total of the bottom beam. The top beam of the mainframe acts as a return line. The hydraulic oil tank is fitted with a level gauge which should only be read when the header is lowered to the ground. The filler cap fitted also has the function of pressurising the RESERVOIR circuit.

IMPORTANT - The filler cap should never be removed when the header is in operation. This could cause damage to the hydraulic components.

In operation the top beam holds quite a large volume of oil before draining to the tank. Due to this the level will probably not be shown on the gauge. This will mean that the header should have standing time to allow oil to drain before topping up level.

A drain plug is situated in the underside of the bottom beam at the L.H. end to assist draining the oil RESERVOIR.
For oil type and capacity see lubrication section.

7.17 HYDRAULIC FILTER.

A return line filter is fitted within the circuit and is mounted on the upper face of the top beam. The filter element should be changed when the indicator arrow points to the red section. Always replace element with the correct item with the same micron rating.

7.18 HYDRAULIC RELIEF VALVES.

The amount of work each of the services, draper or auger, can achieve is regulated by pressure relief valves within the circuit. These relief valves are fitted into the hydraulic control block and are factory set. SEE FIG. 5

The auger relief valve (A) should be set to 240 bar and the draper (B) setting is 90 bar.

These should be checked by dead heading the circuit at the ports labelled "A"(for the auger) and "C"(for the draper) and inserting a gauge at these point "G1"(auger) or "G2"(draper).

IMPORTANT - Do not adjust relief valves without consulting either Shelbourne Reynolds or your local dealer. Hydraulic test equipment will be required to set or check relief valves.

FIG 5

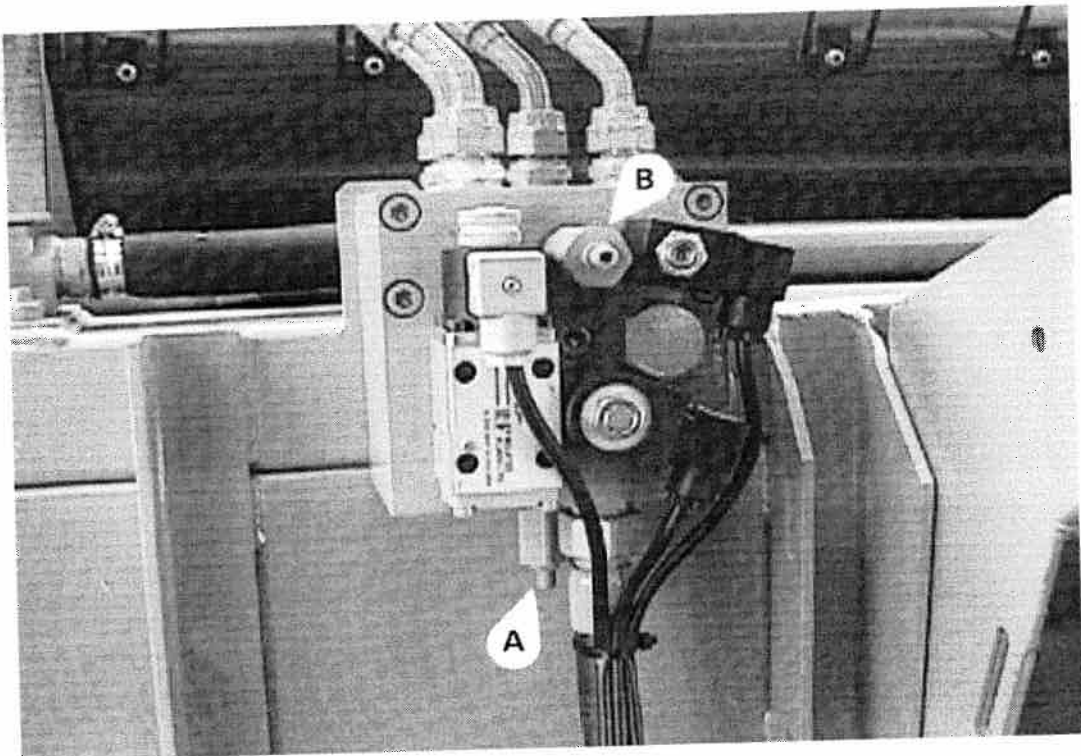

SECTION 8

LUBRICATION

Your Shelbourne Reynolds Pick up Header is designed to reduce down time and therefore requires the minimum amount of lubrication.

Most of the bearings are of the sealed type, requiring no maintenance.



CAUTION - Stop engine before lubricating.

DROP GEARBOX

The oil level of this is displayed on a sight gauge and should only be read when the gearbox is vertical. Use oil type (synthetic) MOBILUBE S.H.C. or equivalent.

The gearbox capacity is 0.25 litre (0.5 pint)

NOTE ;

After the first 100 hours of use the oil should be drained from the gearboxes and replaced with the recommended type.

Oil should then be changed annually.

HYDRAULIC OIL RESERVOIR.

The hydraulic oil tank is fitted with a level gauge which should only be read when the header is lowered to the ground and allowed to stand for a while to drain the top beam. Use oil type MOBILE DTE25 or equivalent

The RESERVOIR capacity is 75 litres (approx. 20 gallons)

Only the recommended lubricant oils should be used.

HYDRAULIC FILTER.

The oil filter should be changed after the first 10 hours of operation. Ensure that the filter element used has a rating of 25 microns.

Elements should then be changed annually or when the indicator shows necessary.

Grease the following points at 10 hour intervals:

1. Universal joints (if PTO shaft fitted).

NOTE:- Grade of grease to be used - Mobilux EP3 or equivalent.

SECTION 9

STORAGE OF THE HEADER

The following procedure should be followed prior to off-season storage of your pick up header to preserve and protect your machine.

1. Remove the pick up header from the combine feeder housing, either onto a trailer or on adequately supportive blocks to prevent header damage.
2. Thoroughly clean the interior and exterior of the header, as any chaff, straw and dirt left on the machine will draw moisture and cause corrosion.
3. Remove conveyor belt or belt tension to prevent it from taking a permanent set.
4. Lubricate the machine thoroughly as described in the lubrication section of this manual.
5. Coat all the bright parts with paint or anti-rust preservative to protect them.

IMPORTANT; DO NOT PUT ANY OIL, PAINT, PRESERVATIVE ETC ON THE PLASTIC BELTING OR FINGERS AS IT MAY DAMAGE THEM

6. Store the header in a dry place protected from the weather and rodents.
7. Use the combine operators manual for storage procedure of your combine.

PICK UP HEADER PARTS MANUAL

Your Shelbourne Reynolds pick up header is designed to fit many different types of combine.

For this reason the machine number index is broken down into sections for identification. Your machine numbers are listed below:

PICK UP HEADER _____
ADAPTOR PLATE _____
DRIVE KIT _____
OTHER KIT OPTIONS _____

This manual contains all parts common to the pick up header and is used in conjunction with the combine fittings manual, which contains the adaptor plate, and drive kit parts and fitting, and any other options available.

Machine Identification

The pick up header machine identification number is engraved on a plate located on the right hand side sheet of the mainframe.

The adaptor plate has a plate on the top right hand corner also with the adaptor plate assembly number engraved on it.

The drive kit can be identified by description, and use of the drive kit identification number marked above.

Ordering Spare Parts

To ensure that you order the correct part from your SRE dealer please use the following procedure.

ALWAYS QUOTE THE MACHINE AND SERIAL NUMBERS WHEN ORDERING.

Refer to the front pages of the parts lists, decide if the part you want is on the:

Pick up Header
Adaptor Kit
Drive Kit

If your part is on the Adaptor Kit, identify by matching the part number from the adaptor plate with that in the top left hand corner of the parts lists. You will find the appropriate drawing accompanying the parts list.

If the part you require is on the drive kit, ensure that you have the parts listing for the correct combine model. Then progress through to the next drawing following that list, for indication of that part.

If the part you require is on the pick up header assembly, identify the appropriate assembly by matching the part number from the pick up header with the page with the same number marked on the top left hand side.

Use the following sub assembly numbers and descriptions to find the area of the machine that your part is required, i.e. you need a part which is fitted to the auger, your part will be in the auger assembly parts list.

Having decided which sub-assembly your part should be under, use the number beside that sub-assembly description which will begin with 2090-- -- to find the parts listing of the sub-assembly further on in the manual. The number will be printed in the top left hand corner, the sub-assemblies are in numerical order.

Having found the correct parts list, you will find the corresponding drawing by processing through the manual to the next drawing.

The drawings indicate the components by item numbers which you will find are repeated in the left hand side of your parts listing, and therefore referring to the correct part.

Shelbourne Reynolds Engineering Limited

ASSY NUMBER: 209900 02		ASSY DESCRIPTION: M/P HYDRAULIC PICK-UP HEADER ASSY					
ITEM	PART NO	DESCRIPTION	QTY	ITEM	PART NO	DESCRIPTION	QTY
1	209009 01	FRAME ASSY ITEMS	1				
2	209010 02	HYDRAULIC RESERVOIR ASSY	1				
3	209005 01	AUGER FINGER ASSY	1				
4	209006 01	AUGER MOUNTING & DRIVE	1				
5	209001 03	CONVEYOR ASSY	1				
6	209003 01	CONVEYOR MOUNTING & DRIVE	1				
7	209007 01	DRAPER SAFETY BAR	1				
8	209012 01	HYDRAULIC CIRCUIT	1				
9	209013 01	ELECTRIC CONTROL SUB	1				
10	209014 01	EMBLEMS SUB	1				
11	209008 01	<u>OPTIONAL EXTRA KIT.</u> CROP SLIDES	1				
12	KIT-01600	FINGER STIFFENER KIT	1				

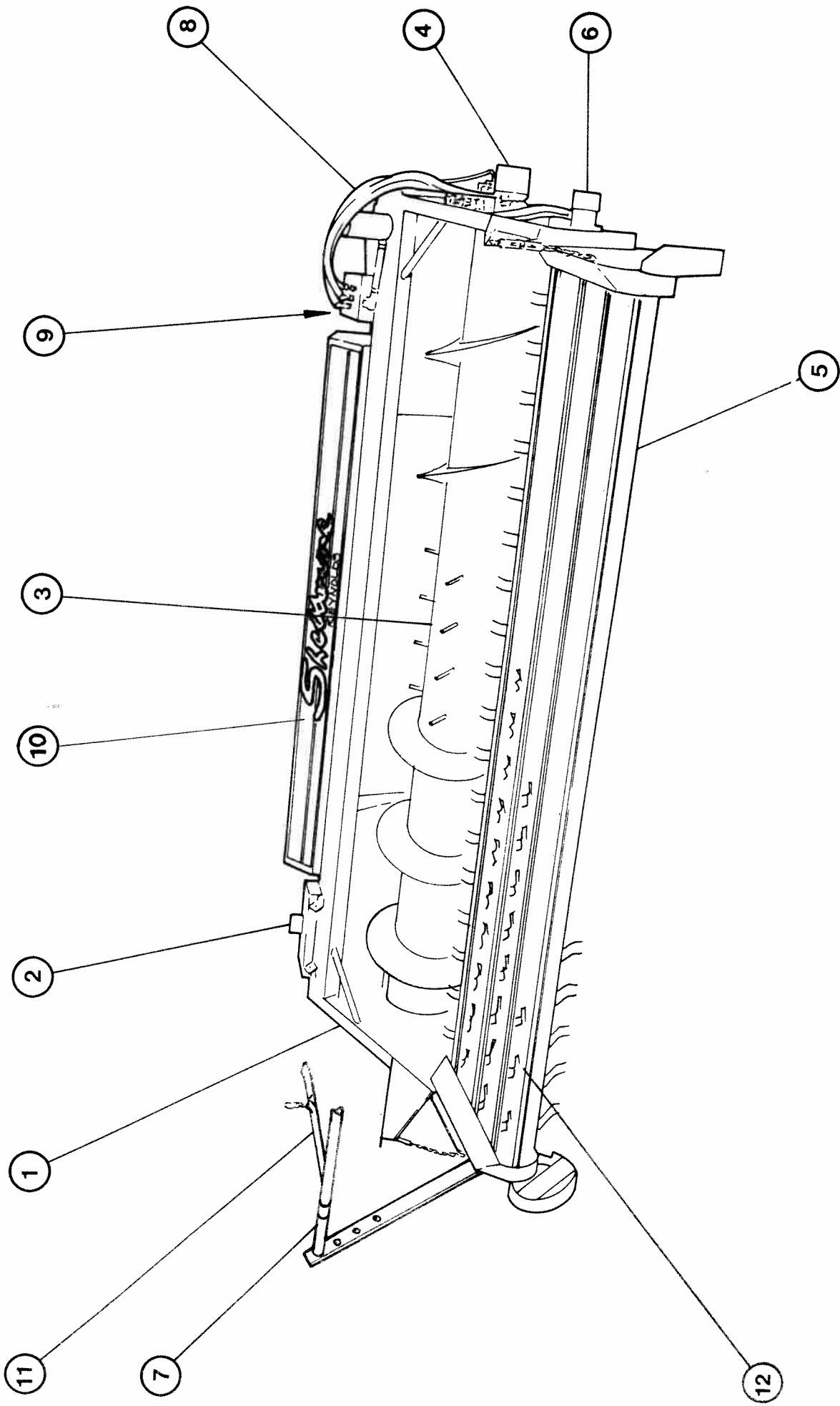

Shelbourne Reynolds Engineering Limited

ASSY NUMBER: 209000 03		ASSY DESCRIPTION: CONVEYOR DRAPER SUB			QTY
ITEM	PART NO	DESCRIPTION	ITEM	PART NO	DESCRIPTION
1	200196 01	DRAPER CANVAS (ENDLESS)			
2					
3	TIN-0020	PLASTIC TINE			
4	SCW-6000	TINE BOLT			
5	NUT-0215	NUT			
6	WSH-0110	WASHER			

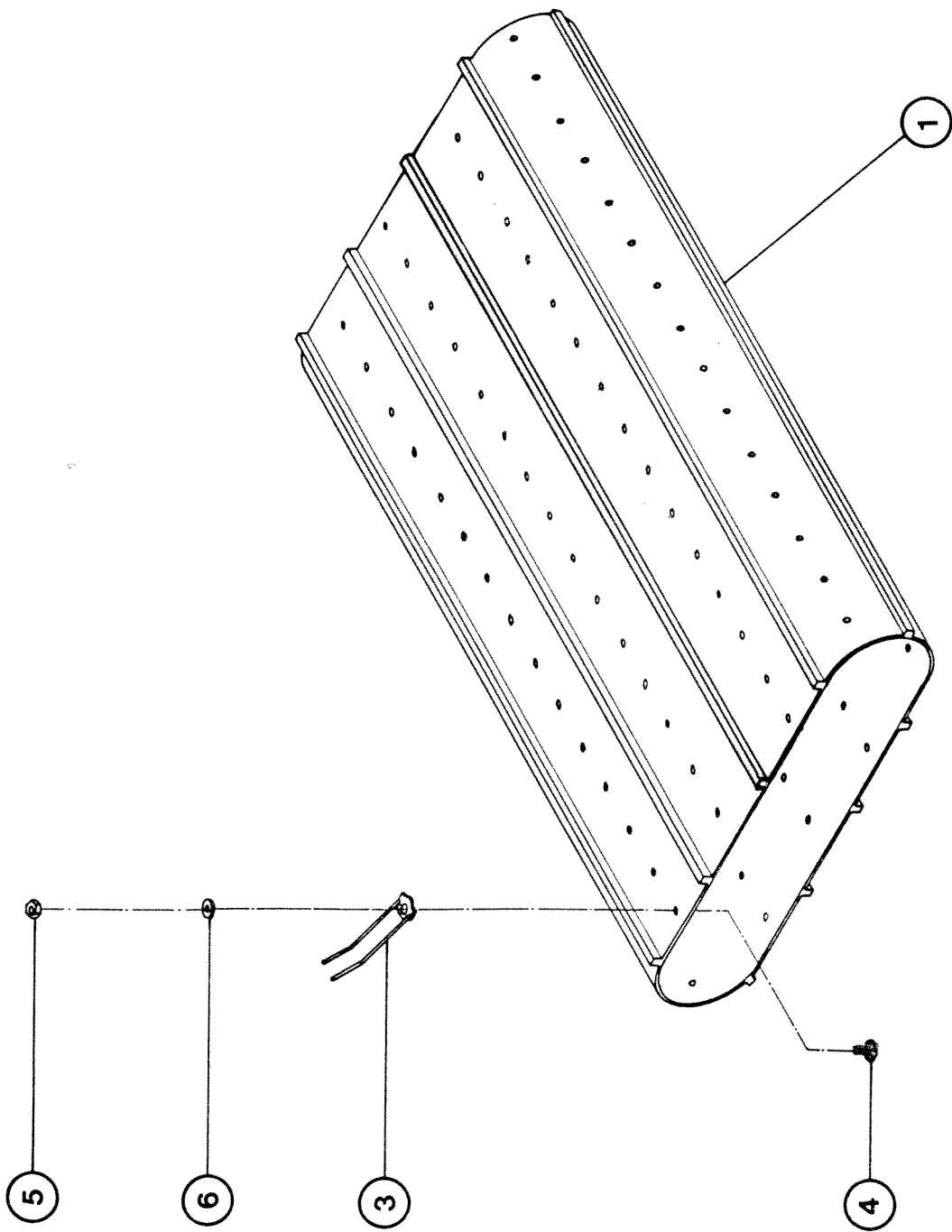

Shelbourne Reynolds Engineering Limited

ASSY NUMBER: 209001 03		ASSY DESCRIPTION: CONVEYOR ASSEMBLY MK.3					
ITEM	PART NO	DESCRIPTION	QTY	ITEM	PART NO	DESCRIPTION	QTY
1	200000 01	SIDE PLATE W/A RH	1				
2	200000 02	SIDE PLATE W/A LH	1				
3	200007 01	TORSION FRAME	1				
4	HSS-0188	SET SCREW	2				
5	WSH-0015	PLAIN WASHER	12				
6	NUT-0265	NYLOC NUT	10				
7	200146 01	DRIVE ROLLER	1				
8	BRG-7050	BEARING	2				
9	CIR-4020	SNAP RING	2				
10	200139 01	IDLE ROLLER	1				
11	BRG-7060	BEARING	2				
12	200107 01	BEARING PLATE	2				
13	200019 01	ADJUSTING PLATE	2				
14	WSH-0061	SPRING WASHER	4				
15	NUT-0167	PLAIN NUT	4				
16	200102 01	SKID ASSY	2				
17	200105 01	SKID ADJUSTER BAR	2				
18	108310 01	SQUARE WASHER	2				
19	HSS-0194	SETSCREW	6				
20	SCW-0516	BUTTON HEAD SCREW	2				
21	209000 03	CONVEYOR DRAPER SUB	1				
22	200137 03	CHAIN	2				
23	ADL-00125	TURNBUCKLE ASSY	2				
24	HSS-0198	SETSCREW	2				
25	HSS-0241	SETSCREW	4				
26	HSS-0250	SETSCREW	2				
27	190119 04	WASHER	8				
28	NUT-0269	NYLOC NUT	4				
29	200136 01	PLATE	2				

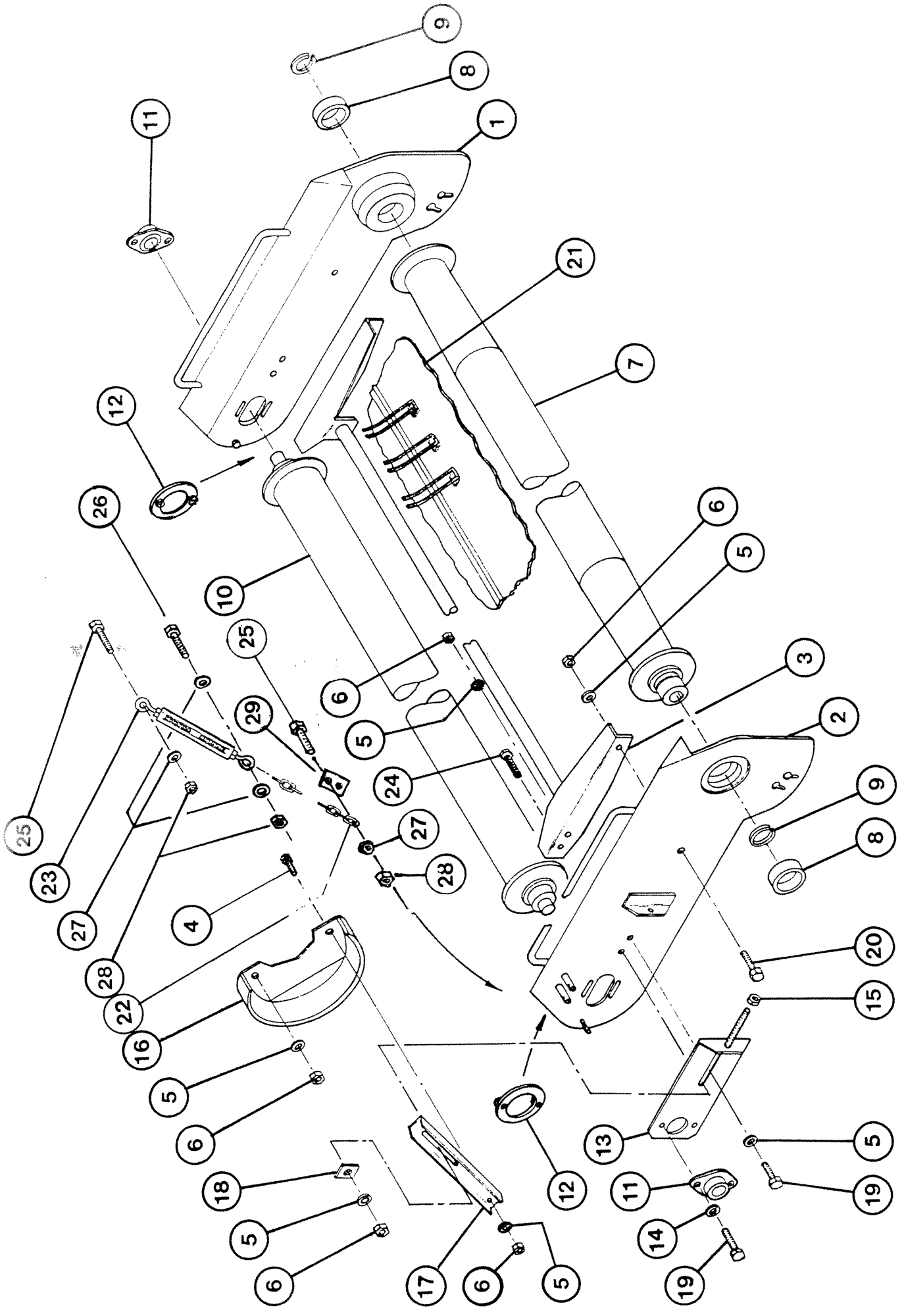

Shelbourne Reynolds Engineering Limited

ASSY NUMBER: 209002 01		ASSY DESCRIPTION: REEL MOTOR SUB					
ITEM	PART NO	DESCRIPTION	QTY	ITEM	PART NO	DESCRIPTION	QTY
1	MOTH08000	HYDRAULIC MOTOR (1997 & ON)	1				
OR	MOT-0121	HYDRAULIC MOTOR (UP TO 1997)	1				
1A	HMS-08000	MOTOR SEAL KIT (+CASE DRAIN)	1				
OR	HMS-08001	MOTOR SEAL KIT (NO CASE DRAIN)	1				
OR	SEA-0520	MOTOR SEAL KIT (UP TO 1997)	1				
1B	K0807032	KEY	1				
2	200028 01	SUPPORT PLATE	1				
3	BSH-1530	BUSH	1				
4	SCW-0519	SCREW	2				
5	NUT-0270	NUT	2				
6	WSH-0018	WASHER	2				

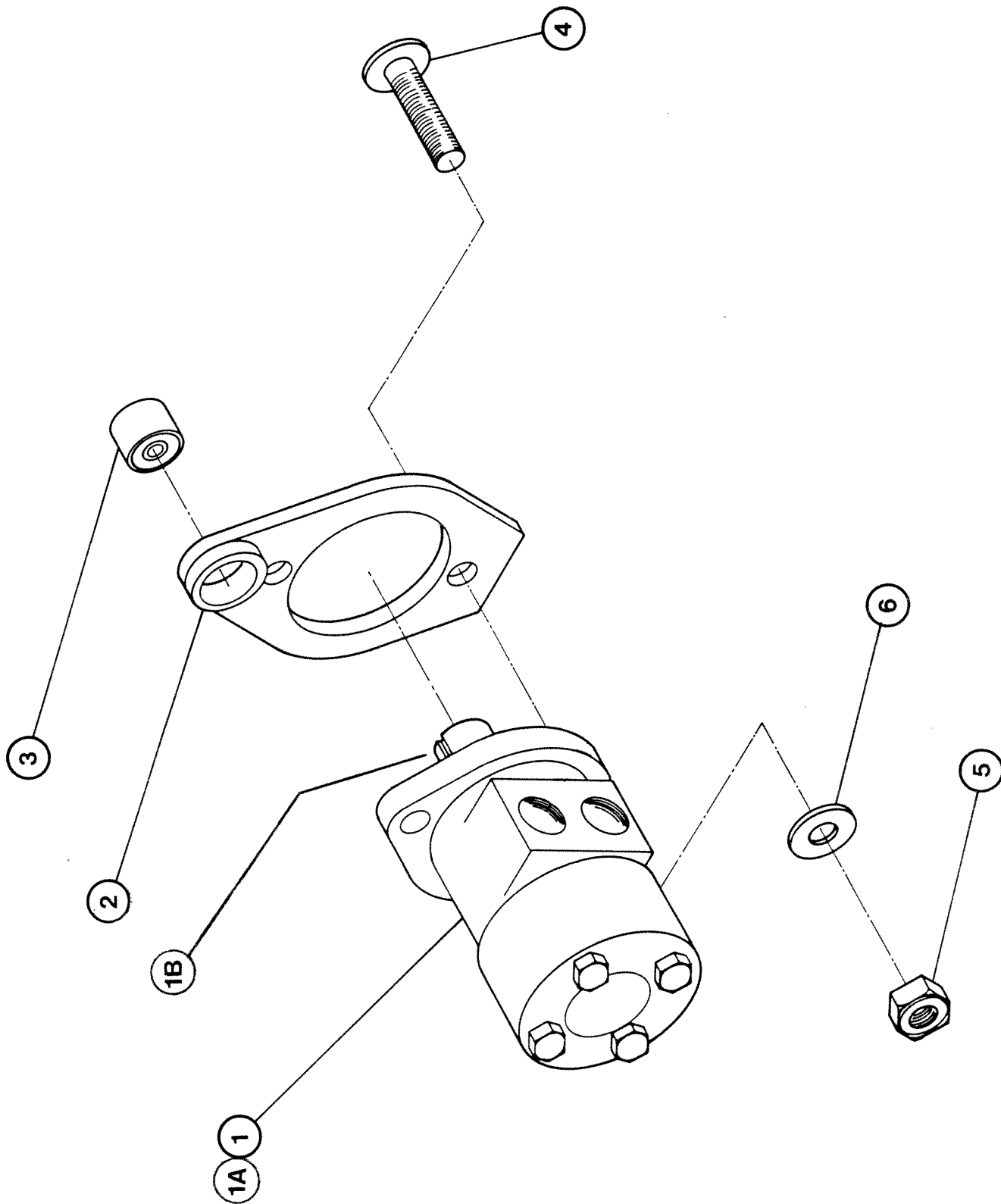

Shelbourne Reynolds Engineering Limited

ASSY NUMBER: 209003 01		ASSY DESCRIPTION: CONVEYOR ASSY MOUNTING & DRIVE					
ITEM	PART NO	DESCRIPTION	QTY	ITEM	PART NO	DESCRIPTION	QTY
1	200031 01	BEARING SUPPORT LH	1				
2	200124 01	BUSH	2				
3	SCW-1730	SCREW	4				
4	200031 02	BEARING SUPPORT RH	1				
5	200030 01	COVER PLATE	1				
6	HSS-0135	SET SCREW	4				
7	WSH-0058	WASHER	4				
8	209002 01	REEL MOTOR ASSY	1				
9	BLT-2247	BOLT	1				
10	190119 04	WASHER	1				
11	WSH-0065	WASHER	1				

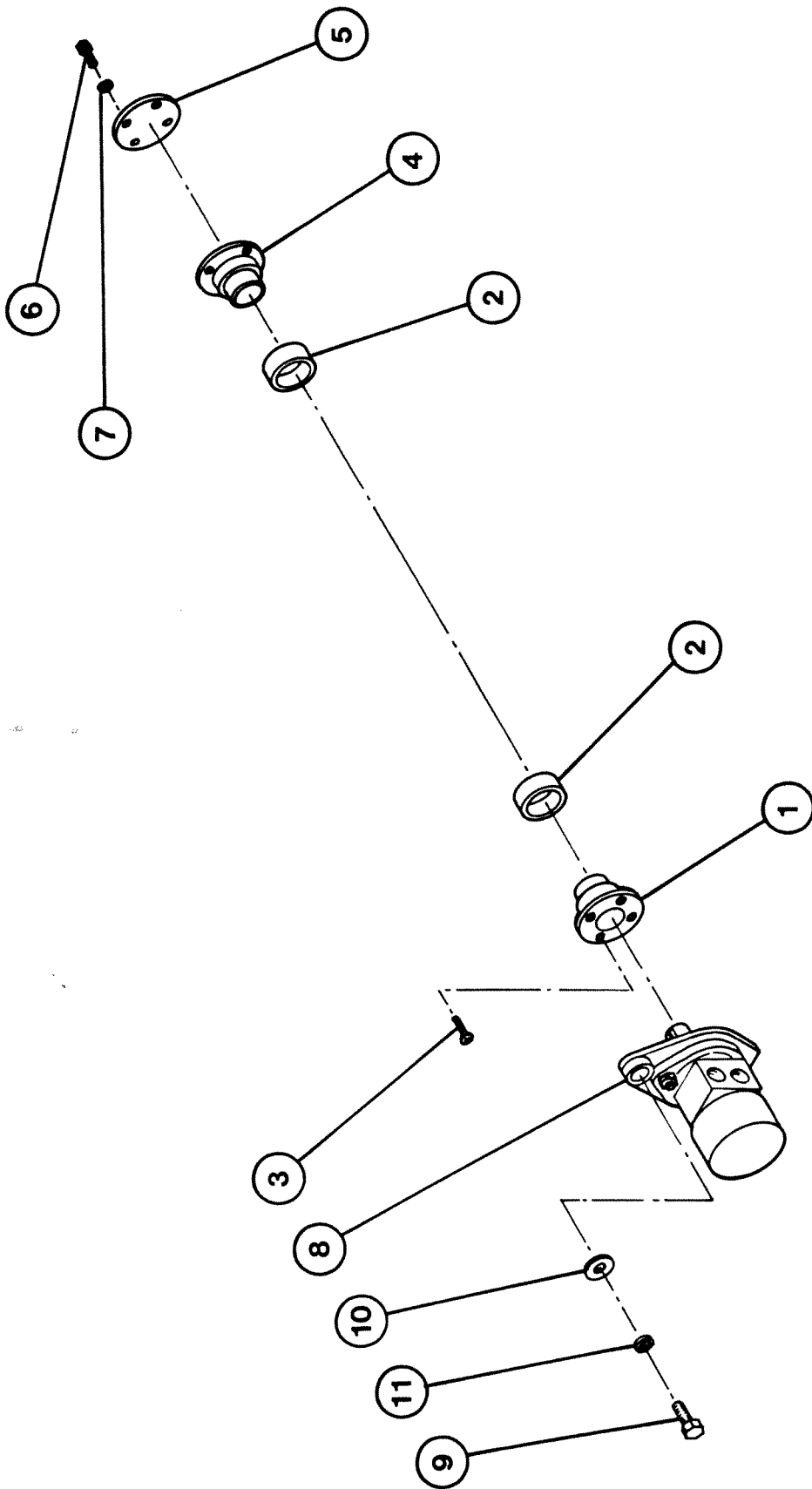

Shelbourne Reynolds Engineering Limited

ASSY NUMBER: 209004 01		ASSY DESCRIPTION: AUGER MOTOR SUB					
ITEM	PART NO	DESCRIPTION	QTY	ITEM	PART NO	DESCRIPTION	QTY
1	MOTH16041	HYDRAULIC MOTOR (1997 & ON)	1				
OR	MOTH16441	HYDRAULIC MOTOR (UP TO 1997)	1				
1A	HMS-16000	MOTOR SEAL KIT (1997 & ON)	1				
OR	HMS-16441	MOTOR SEAL KIT (UP TO 1997)	1				
1B	K1008045	KEY (1997 & ON)	1				
OR	K1007032	KEY (UP TO 1997)	1				
2	200040 01	SUPPORT PLATE	1				
3	BSH-1530	BUSH	2				
4	SCW-0519	SCREW	4				
5	NUT-0270	NUT	4				
6	WSH-0018	WASHER	4				

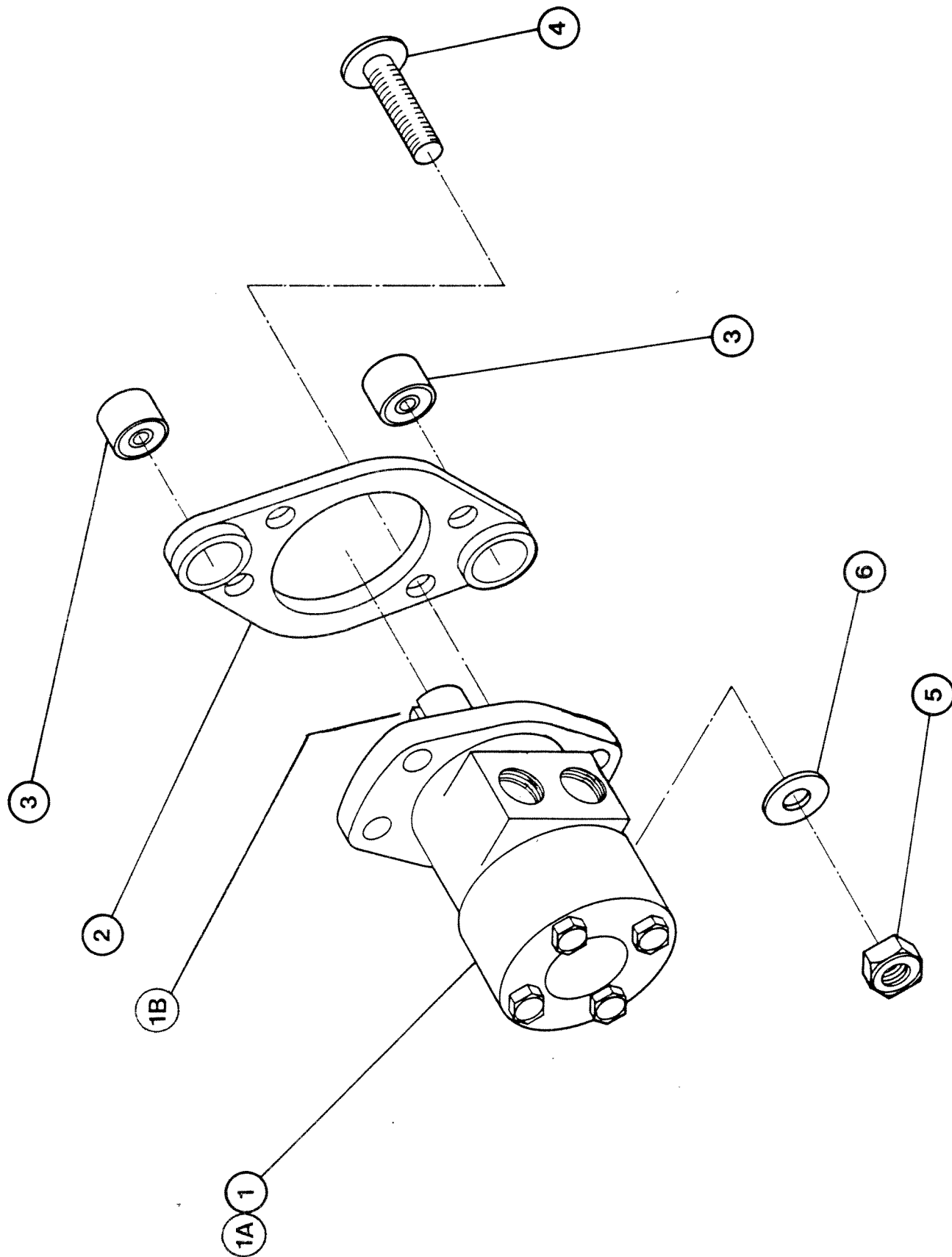

Shelbourne Reynolds Engineering Limited

ASSY NUMBER: 209005 01		ASSY DESCRIPTION: AUGER ASSY (RETRACTABLE FINGERS)					
ITEM	PART NO	DESCRIPTION	QTY	ITEM	PART NO	DESCRIPTION	QTY
1	200032 01	AUGER W/A	1				
2	132019 01	COVER PLATE	1				
3	BRG-0218	BEARING	1				
4	BRG-7080	BEARING	2				
5	200114 01	AUGER CRANK	1				
6	132010 01	FINGER BUSH	15				
7	132001 01	FINGER	15				
8	132011	FINGER PLATE CONCAVE	15				
9	132012	FINGER PLATE CONVEX	15				
10	132013	FINGER GUIDE	15				
11	K0606030	KEY	1				
12	PIN-1167	PIN	15				
13	200121 01	AUGER CLAMP	1				
14	200113 01	AUGER SHAFT	1				
15	BLT-2197	BOLT	3				
16	NUT-0265	NUT	3				
17	HSS-0140	SET SCREW	9				
18	NUT-0263	NUT	10				
19	WSH-0012	WASHER	15				
20	SCW-4960	SCREW	44				
21	NUT-0260	NUT	30				
22	WSH-0009	WASHER	14				
23	WSH-0056	WASHER	14				
24	K0807060	KEY	2				
25	200281 01	AUGER FLIGHT EXTENSION LH	1				
26	200281 02	AUGER FLIGHT EXTENSION RH	1				
27	SCBA08172	BUT. SCTKT HD SCREW	6				
28	WSH-0058	WASHER	2				

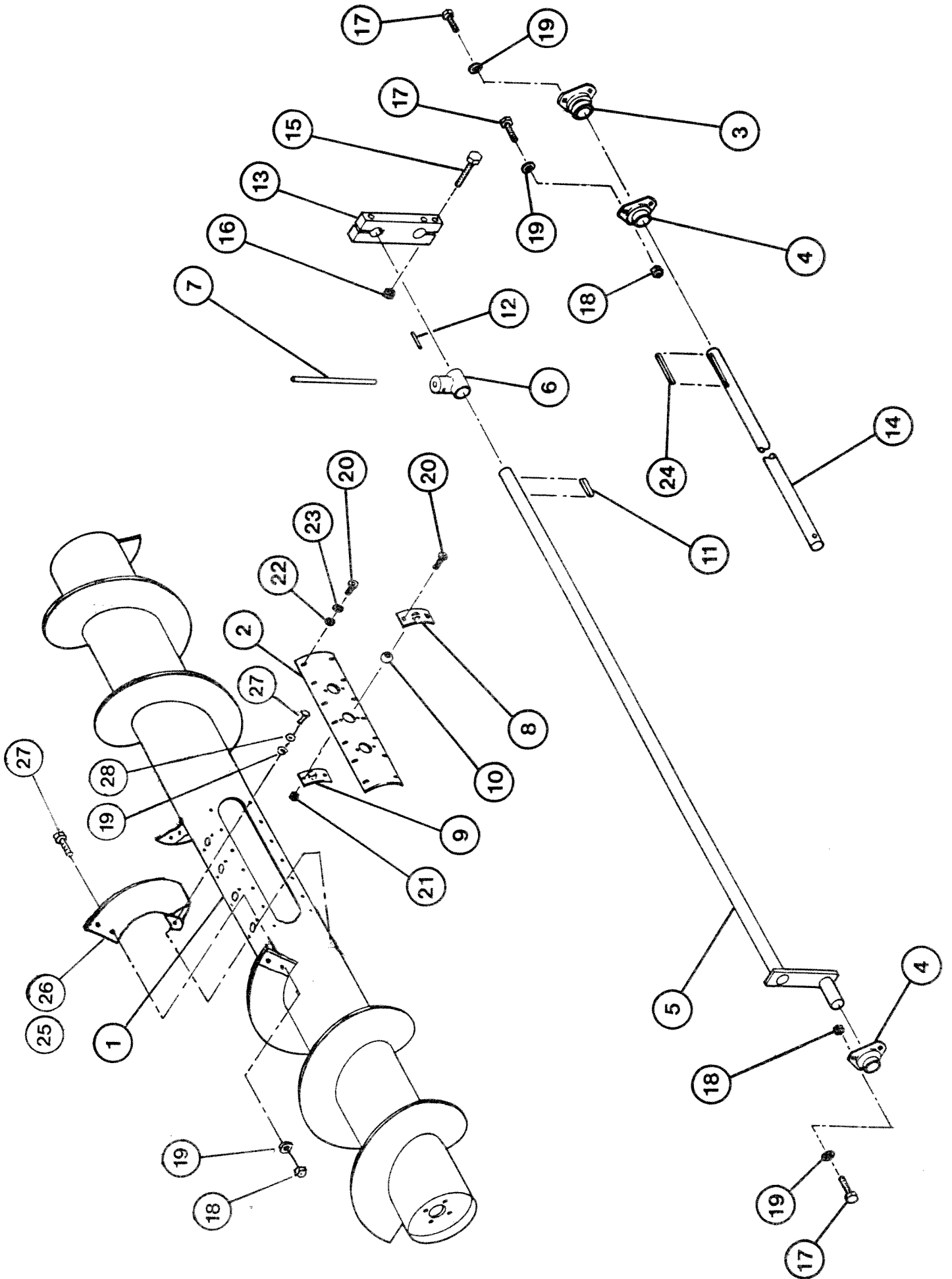

Shelbourne Reynolds Engineering Limited

ASSY NUMBER: 209006 01		ASSY DESCRIPTION: AUGER MTG & DRIVE SUB					
ITEM	PART NO	DESCRIPTION	QTY	ITEM	PART NO	DESCRIPTION	QTY
1	200043 01	DRIVING HUB	1				
2	SCW-1955	SCREW	4				
3	BRG-7090	BEARING	1				
4	CIR-0050	CIRCLIP	1				
5	200038 01	ADJUSTER PLATE RH	1				
6	200034 01	ADJUSTER PLATE LH	1				
7	190585 06	VERTICAL ADJUSTER	2				
8	190585 04	HORIZONTAL ADJUSTER	2				
9	BLT-3812	BOLT	4				
10	NUT-0269	NUT	7				
11	WSH-0018	WASHER	6				
12	NUT-0170	NUT	8				
13	HSS-0241	SET SCREW	1				
14	200120 01	FINGER ADJUSTER	1				
15	SCW-4540	GRUB SCREW	2				
16	209004 01	AUGER MOTOR SUB	1				
17	190119 04	WASHER	2				

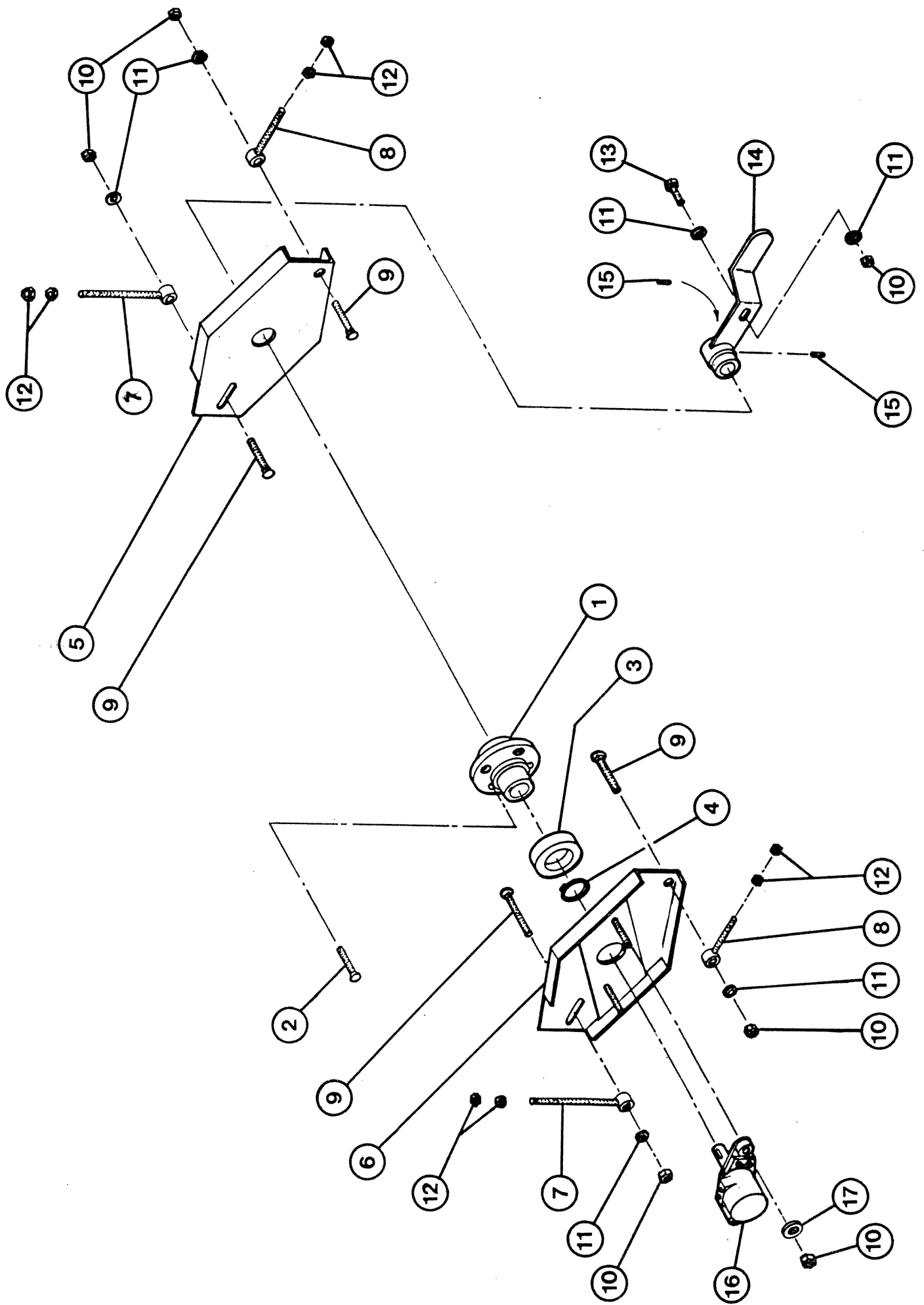

Shelbourne Reynolds Engineering Limited

ASSY NUMBER: 209007 01		ASSY DESCRIPTION: DRAPER SAFETY BAR & STRIPPER PLATE					
ITEM	PART NO	DESCRIPTION	QTY	ITEM	PART NO	DESCRIPTION	QTY
1	109005 01	CROP SLIDE SUPPORT	2				
2	200010 01	SAFETY TUBE	1				
3	PIN-4511	LYNCH PIN	6				
4	200078 01	STRIPPER PLATE	1				
5	200079 01	STUB END SWIVEL	2				
6	NUT-0370	NUT	2				
7	200080 01	SPRING PLATE	5				
8	SCW-0525	SCREW	5				
9	108304 04	CANVAS STRIPPER	1				
10	108303 04	BACKING STRIP	1				
11	HSS-0086	SET SCREW	20				
12	WSH-0009	PLAIN WASHER	20				
13	NUT-0260	NYLOC NUT	20				

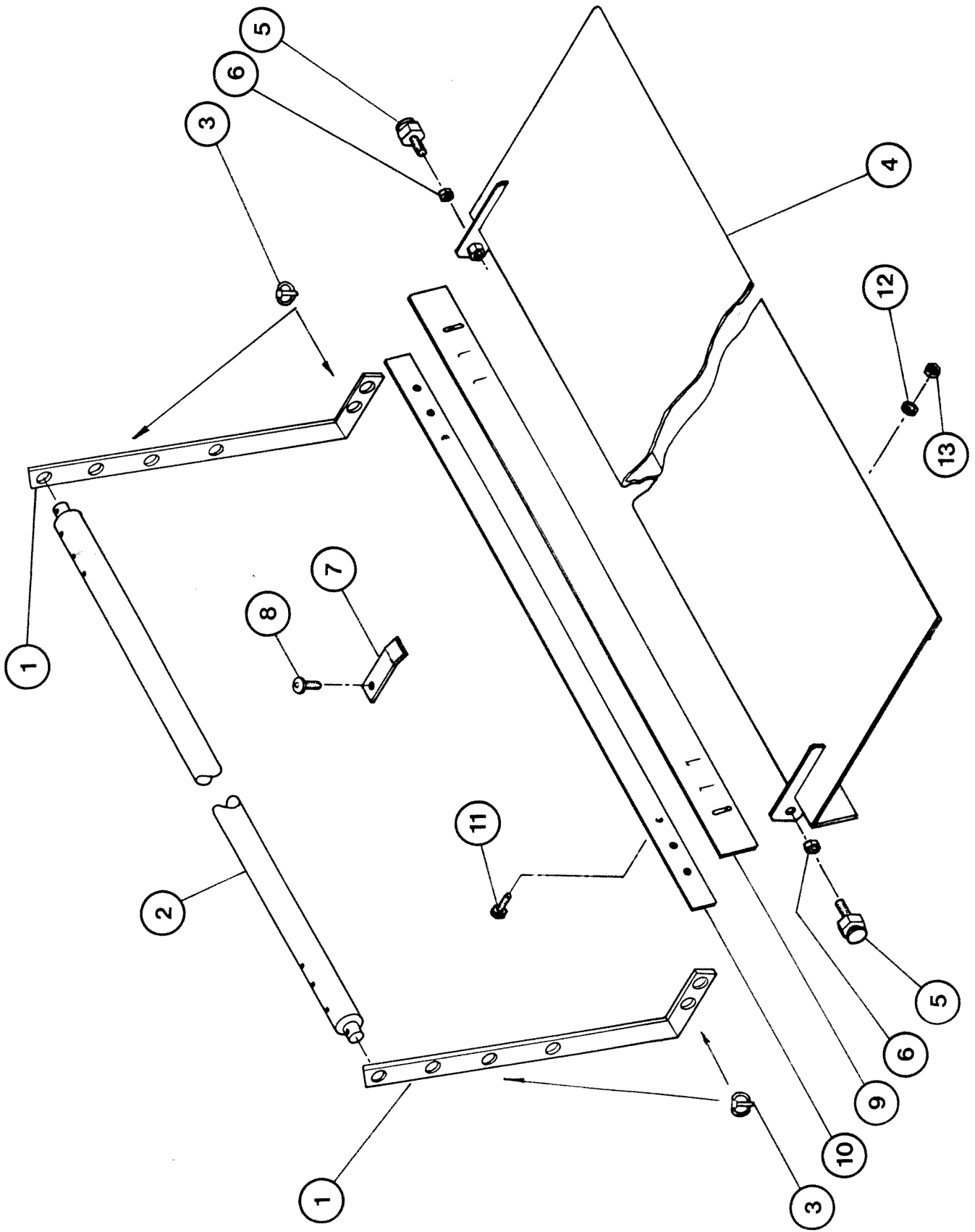

Shelbourne Reynolds Engineering Limited

AASY NUMBER: 209008 01		ASSY DESCRIPTION: CROP SLIDES					
ITEM	PART NO	DESCRIPTION	QTY	ITEM	PART NO	DESCRIPTION	QTY
1	109007	CROP SLIDE	8				
2	109006	SLIDE SWIVEL	8				
3	PIN-1170	SPLIT PIN	16				
4	HSS-0145	SET SCREW	16				
5	NUT-0263	NUT	16				
6	WSH-0012	WASHER	16				
7	200083 01	REAR SLIDE SUPPORT	1				
8	200084 01	REAR SLIDE VERTICAL SPRT	2				
9	HSS-0191	SET SCREW	6				
10	NUT-0265	NUT	6				
11	WSH-0015	WASHER	6				

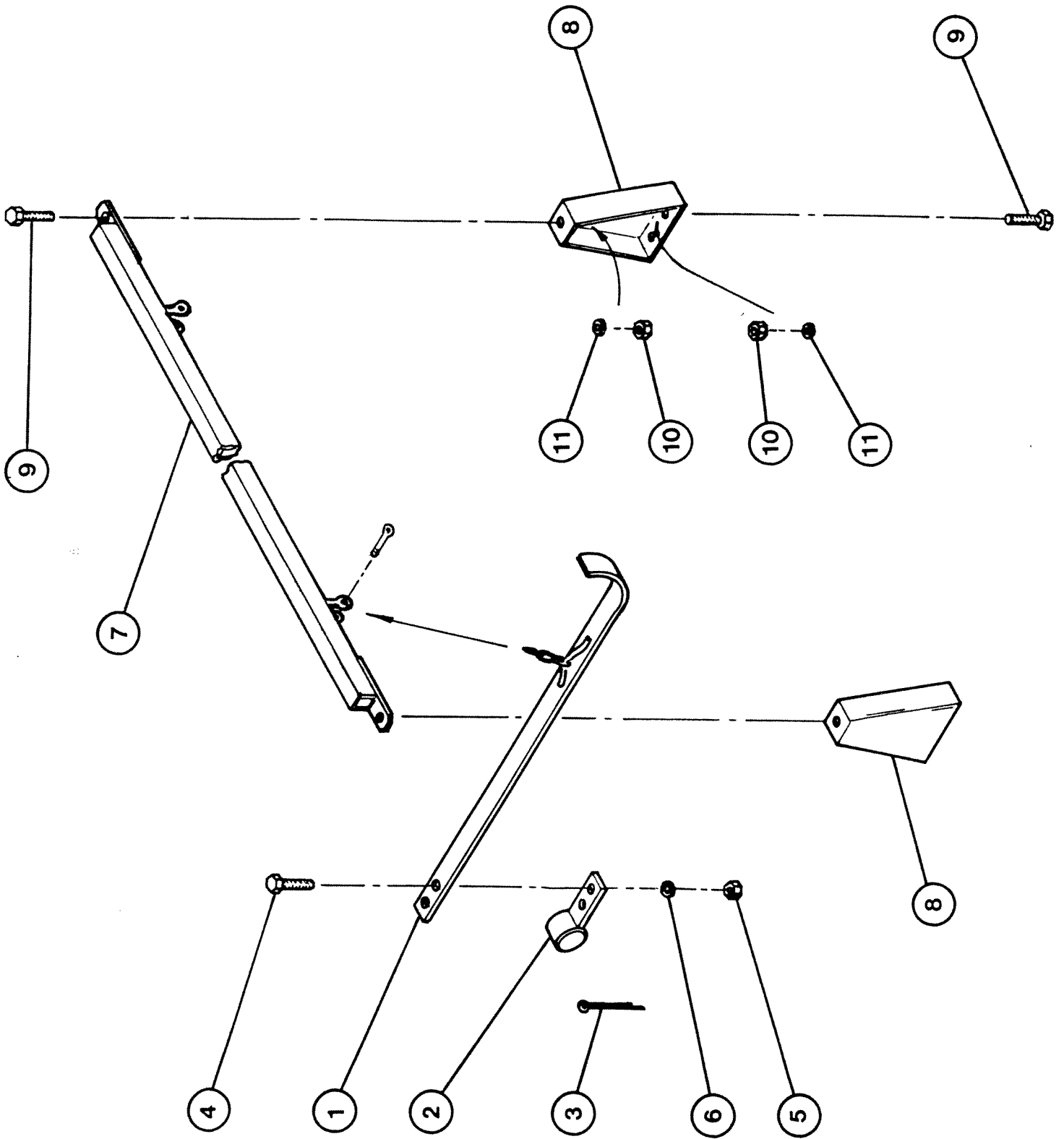

Shelbourne Reynolds Engineering Limited

ASSY NUMBER: 209009 01		ASSY DESCRIPTION: FRAME ASSEMBLY ITEMS					
ITEM	PART NO	DESCRIPTION	QTY	ITEM	PART NO	DESCRIPTION	QTY
1	200289 01	MAIN FRAME W/A 1998	1				
OR	200267 01	MAINFRAME W/A					
OR	200072 01	MAIN FRAME W/A	2				
2	200258 01	SKID W/A	8				
OR	200089 01	SKID W/A	8				
3	HSS-0314	SET SCREW	8				
4	WSH-0024	WASHER	8				
5	WSH-0070	WASHER	8				
6							
7							
8							
9							
10	200087 01	SCRAPER	2				
11	BLT-4710	COACH BOLT	8				
12	NUT-0263	NUT	8				
13	WSH-0012	WASHER	16				
14	200086 01	DRAPER SUPPORT LH	1				
15	200086 02	DRAPER SUPPORT RH	1				
16	HSS-0191	SET SCREW	6				
17	NUT-0265	NUT	6				
18	WSH-0015	WASHER	6				
19							
20	200030 01	COVER PLATE	2				
21	HSS-0125	SET SCREW	8				

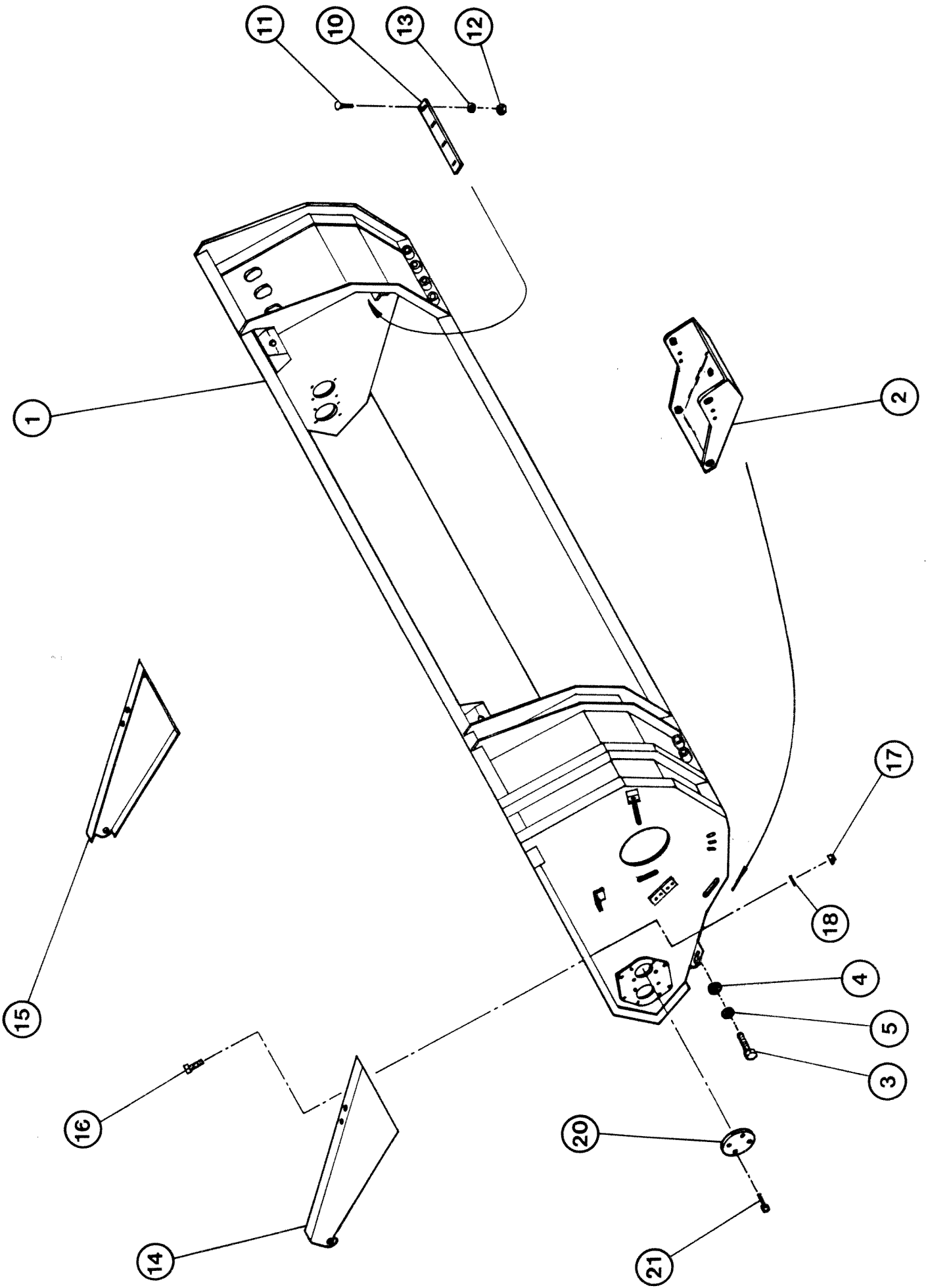

Shelbourne Reynolds Engineering Limited

ASSY NUMBER: 209010 02		ASSY DESCRIPTION: HYDRAULIC RESERVOIR ASSY					
ITEM	PART NO	DESCRIPTION	QTY	ITEM	PART NO	DESCRIPTION	QTY
1	200128 01	HYDRAULIC RESERVOIR	1				
2	BRT-0005	FILLER PRESURISED WITH STRAINER	1				
3	GAU-0010	FLUID LEVEL TEMP GUAGE	1				
4	HOS-1050	HOSE	0.085				
4	HOS-1050	HOSE	0.085				
4	HOS-1050	HOSE	0.085				
4	HOS-1050	HOSE	0.085				
5	HOS-1050	HOSE	0.095				
5	HOS-1050	HOSE	0.095				
5	HOS-1050	HOSE	0.095				
6							
7							
8	CLP-0120	JUBILEE CLIP	14				
9	SCW-0518	SCREW	2				
10	HSS-0238	SET SCREW	2				
11	WSH-0018	WASHER	8				
12	NUT-0269	NUT	4				

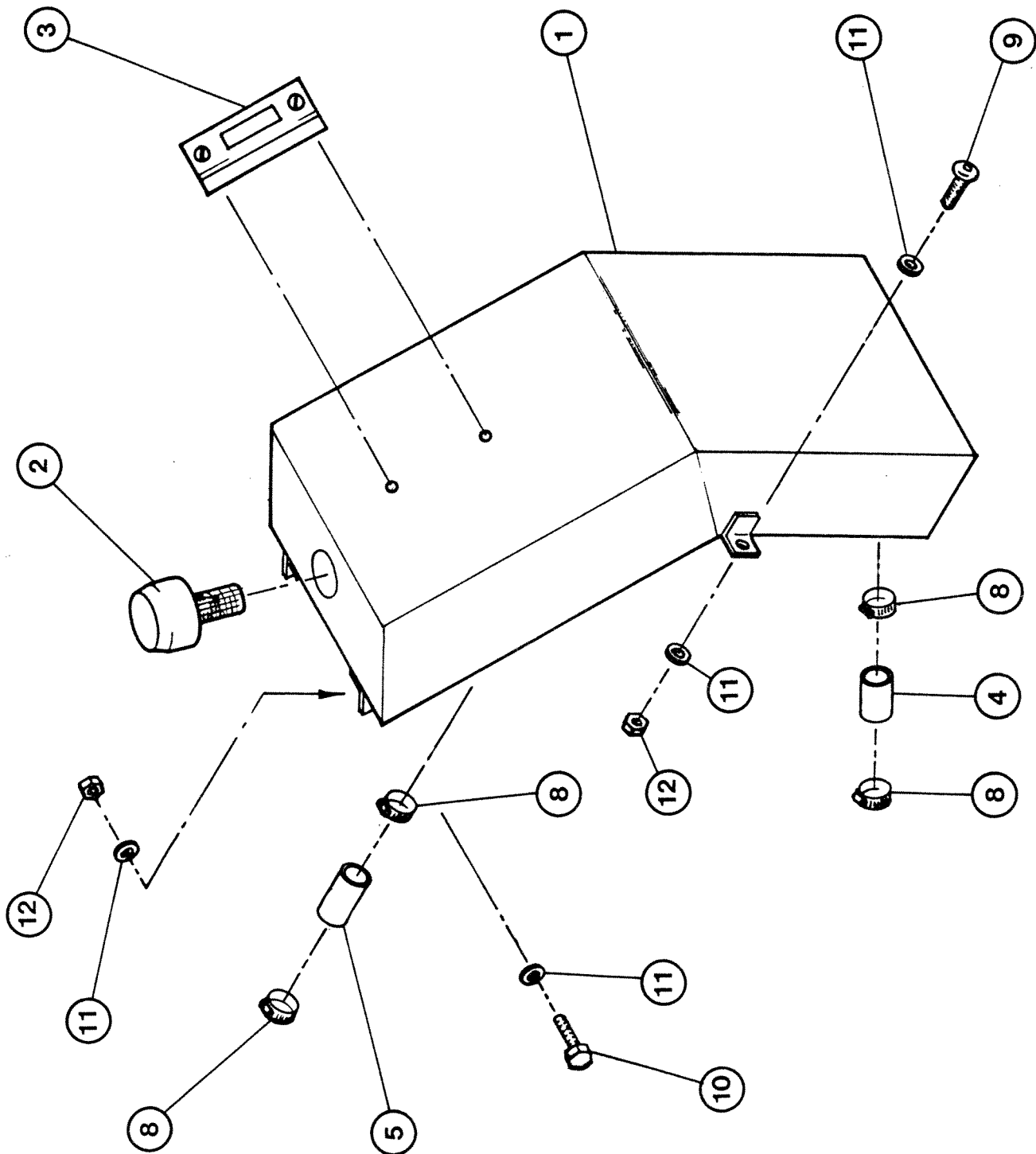

Shelbourne Reynolds Engineering Limited

ASSY NUMBRER: 209011 01		ASSY DESCRIPTION: CONTROL VALVE BLOCK					
ITEM	PART NO	DESCRIPTION	QTY	ITEM	PART NO	DESCRIPTION	QTY
1	HVB-19000	HYDRAULIC CONTROL VALVE BLOCK ASSEMBLY.	1				
1a	HVB-90000	VALVE BLOCK/MANIFOLD	1				
1b	HVC-00500	RELIEF VALVE (SET - 240BAR)	1				
1c	HVC-00510	RELIEF VALVE (SET - 90BAR)	1				
1d	HVC-01000	SOLENOID VALVE	1				
1e	HVC-01500	PRESSURE COMPENSATOR VALVE	1				
1f	HVC-02000	PROP.FLOW CONTROL VALVE	1				
1g	HVC-02500	DIRECTIONAL CONTROL VALVE	1				
1h	HVC-01001	SOLENOID VALVE COIL	1				
1i	HVC-01002	SOLENOID VALVE CONNECTOR	1				
2	200197 01	WIRE LOOM	1				

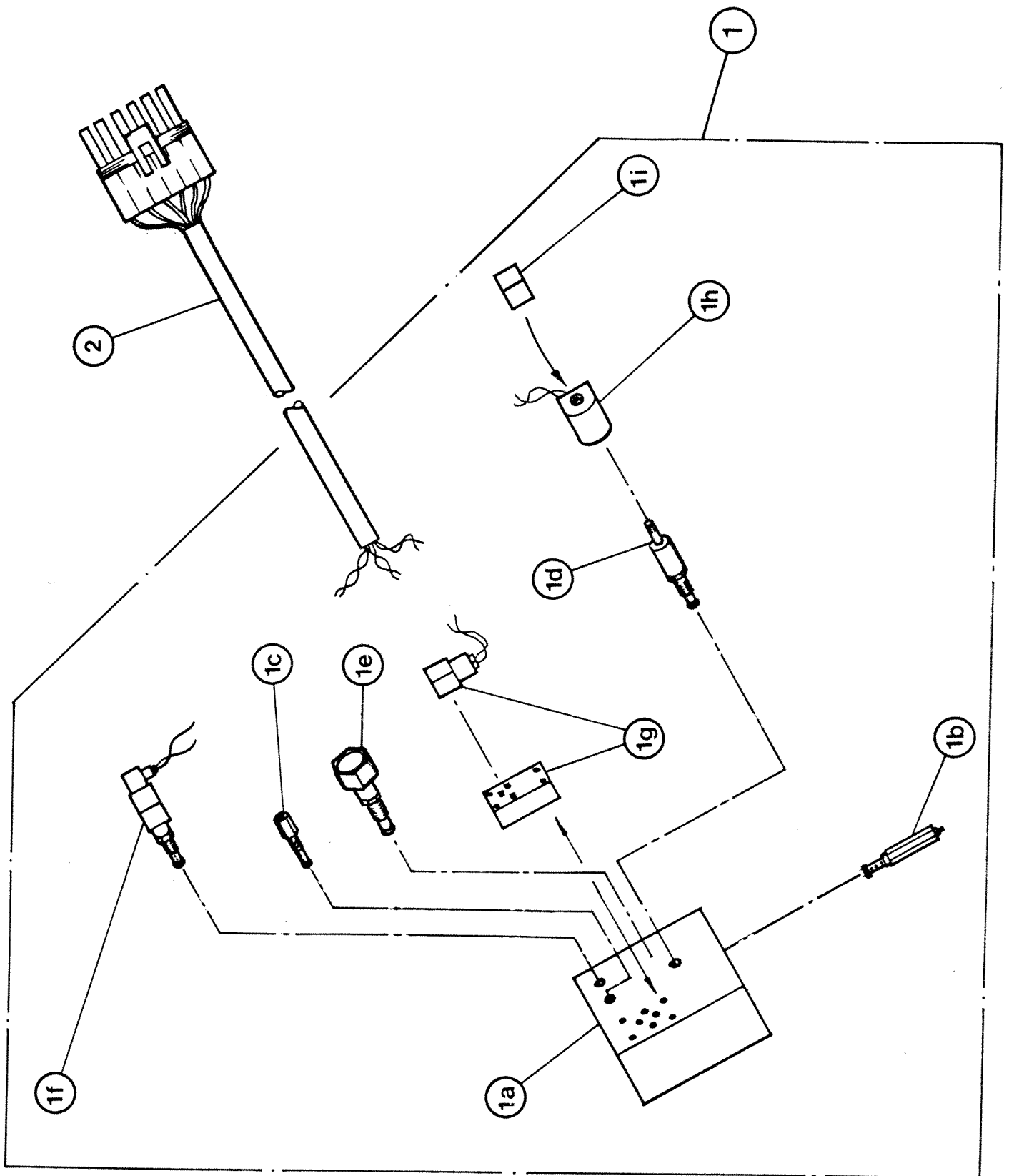

Shelbourne Reynolds Engineering Limited

ASSY NUMBER: 209012 01		ASSY DESCRIPTION: HYDRAULIC CIRCUIT SUB					
ITEM	PART NO	DESCRIPTION	QTY	ITEM	PART NO	DESCRIPTION	QTY
1	209011 01	VALVE BLOCK ASSY	1				
2	SCCA10592	CAP HEAD SCREW	4				
3	WSH-0015	PLAIN WASHER	4				
4	NUT-0265	NYLOC NUT	4				
5	WSH-1015	DOWTY WASHER	8				
6	HMA-0067	FITTING	8				
7	HHDF14705	HOSE	2				
8	HHDF09305	HOSE	2				
9	HVB-22035	HYD.RELIEF VALVE BLOCK (1997 & ON)	1				
OR	HVB-22030	HYD.RELIEF VALVE BLOCK (UP TO 1997)	1				
10	WSH-1025	DOWTY WASHER	1				
11	FIT-0546	FITTING	1				
12	HFAI14013	HOSE FITTING	1				
13	HOS-1030	HOSE	0.18				
14	CLP-0070	JUBILEE CLIP	2				
15	HMA-0074	FITTING	1				
16	WSH-1020	DOWTY WASHER	1				
17	FIL-0110	TOP FLOW FILTER	1				
18	FIL-0120	FILTER ELEMENT (SPARES ONLY)					
19	HSS-0086	SET SCREW	4				
20	WSH-0056	SPRING WASHER	4				
21							
22	FIT-0080	LOCKNUT	1				
23	FIT-0548	FITTING	1				
24	WSH-1010	DOWTY WASHER	1				
25	FIT-0251	BLANK.PLUG	1				
26	KIT-02512	CHECK VALVE LOOP SUB	1				
27	HCPD01800	DOUBLE PIPE CLAMP (1996)	1				
OR	HCPA02200	SINGLE PIPE CLAMP (PRE-1996)	2				
28	SCW-0136	SCREW (1996)	1				
OR	SCW-0089	SCREW (PRE-1996)	4				

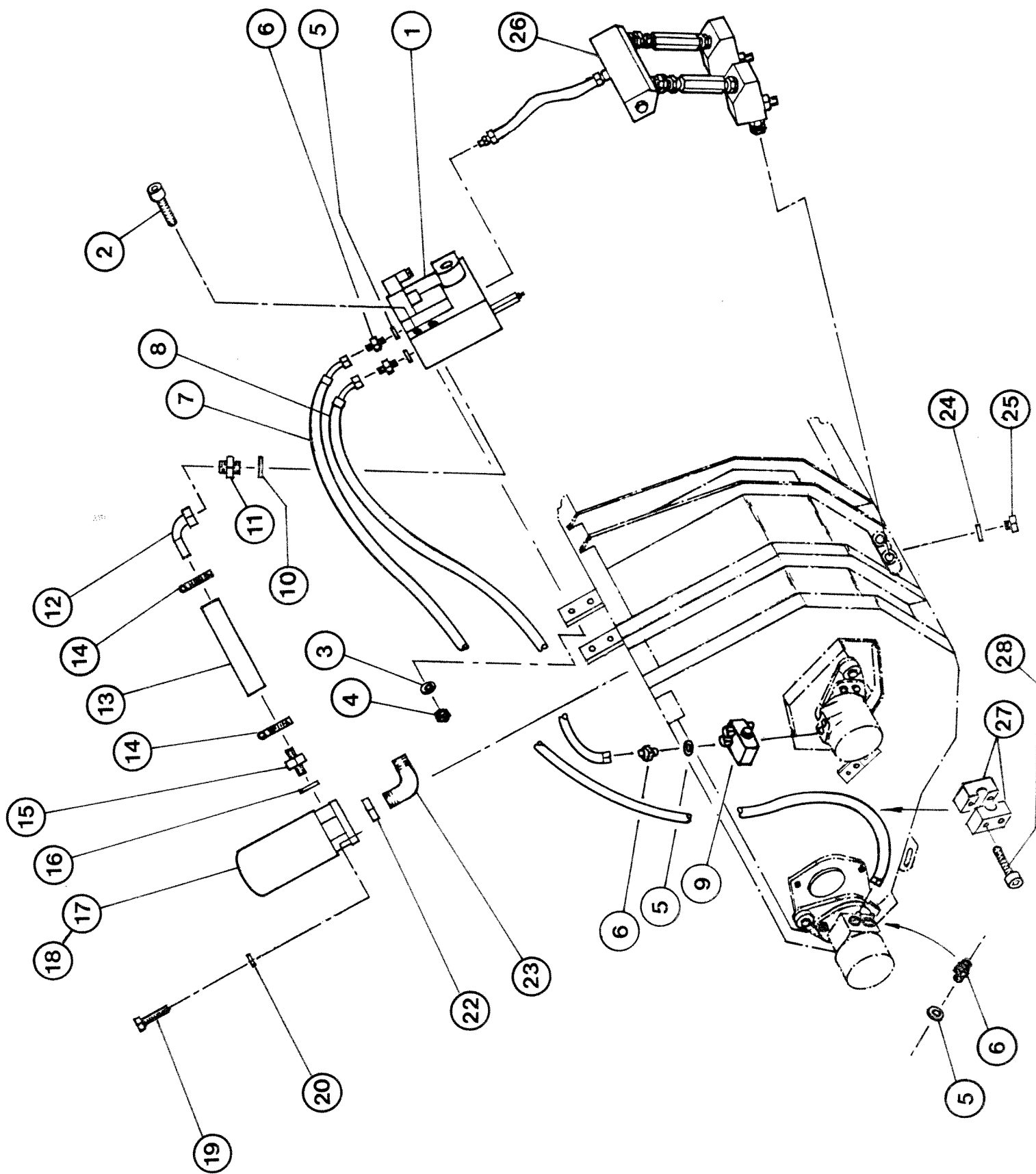

Shelbourne Reynolds Engineering Limited

ASSY NUMBER: 209013 01		ASSY DESCRIPTION: ELECTRIC CONTROL SUB					
ITEM	PART NO	DESCRIPTION	QTY	ITEM	PART NO	DESCRIPTION	QTY
1	200198 01	CONTROL BOX ASSY.	1				
2	200250 01	POWER LEAD (6 MT.)	1				
3	200257 01	CONNECTING LEAD	1				

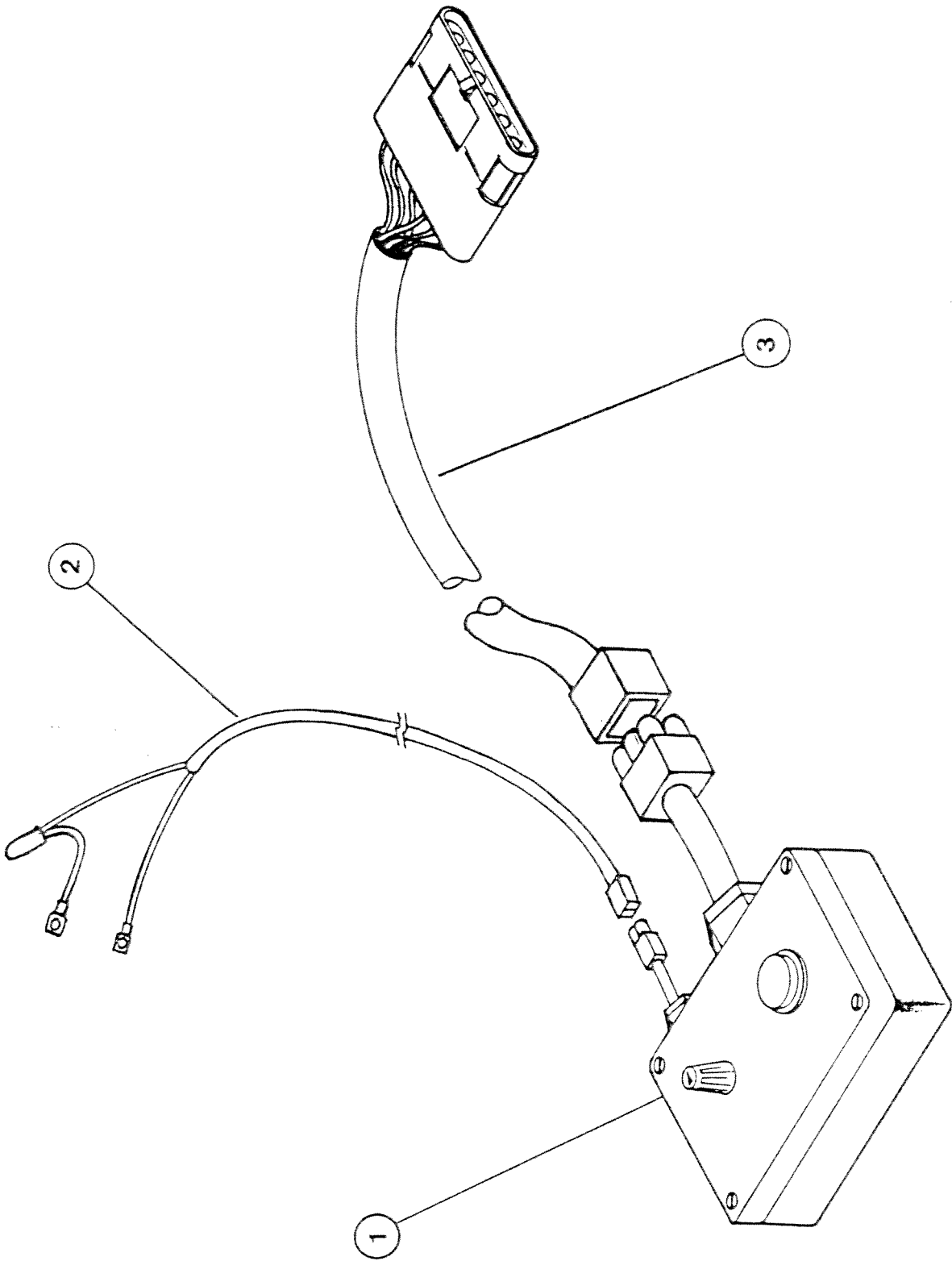

Shelbourne Reynolds Engineering Limited

ASSY NUMBER: 209014 01		ASSY DESCRIPTION: EMBLEMS SUB	
ITEM	PART NO	DESCRIPTION	QTY
1	191981 01	EMBLEM (SHELBOURNE, CENTRE)	1
2	590000 01	EMBLEM (STRIPE EXTENSION)	1
3	190702 04	EMBLEM (SLING POINT)	2
4	134024 05	IDENTIFICATION PLATE	1
5	POP-0006	POP RIVET	4
6	193390 01	EMBLEM (DONT HANG CHAIN)	1
7	193391 01	EMBLEM (PTO GUARD)	1
8	127075 12	EMBLEM (GREASE 10 HOURS)	1
9	610250 01	EMBLEM (SAFETY MAINTENANCE)	1
10	610257 01	EMBLEM (READ MANUAL)	1
11	193393 01	EMBLEM (AUGER DANGER)	2
12	200291 01	EMBLEM (KEEP CLEAR)	2

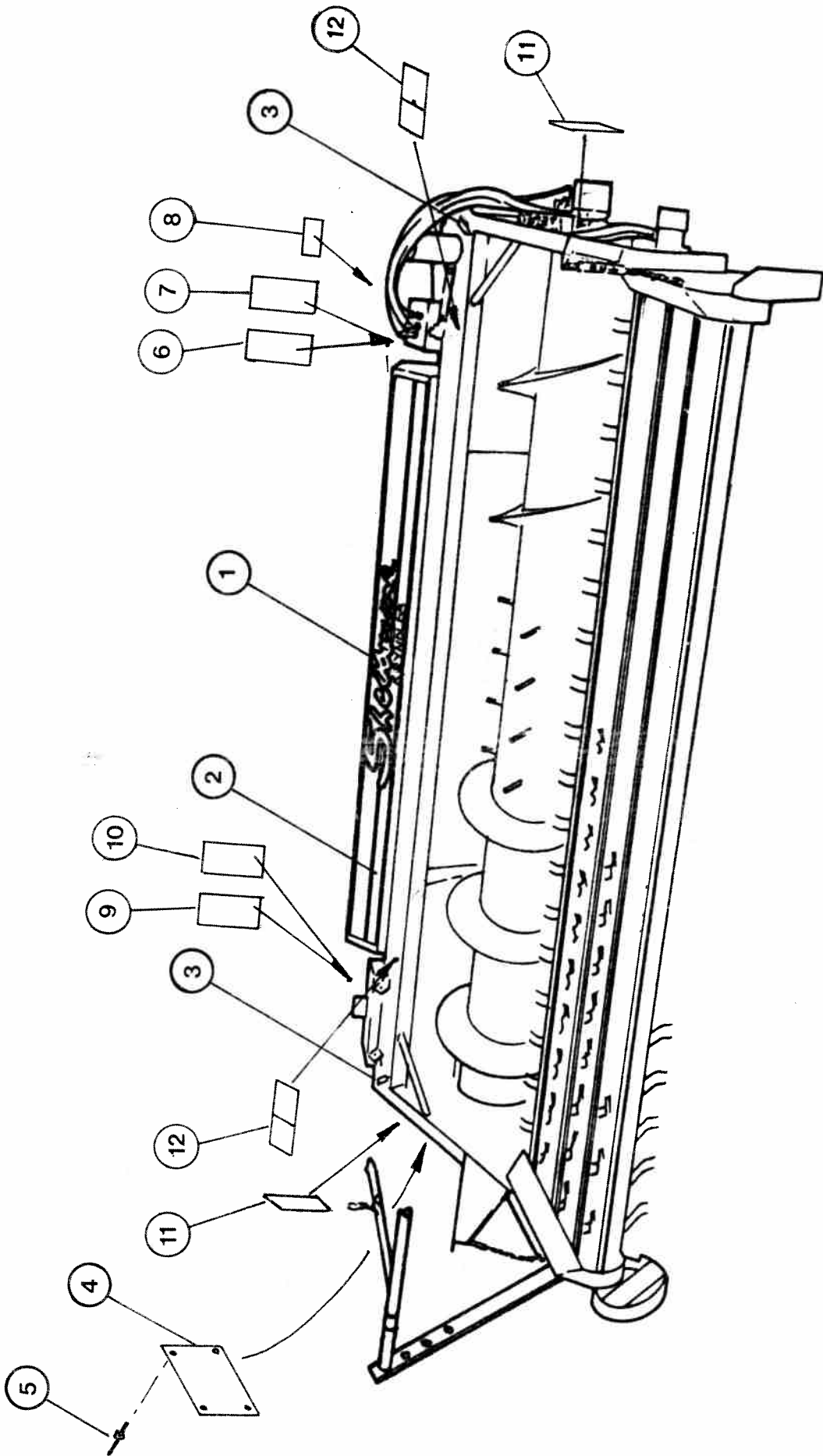

Shelbourne Reynolds Engineering Limited

KIT-01600		SUB ASSY DESCRIPTION: FINGER STIFFENER KIT FOR HYD P.U.H					
ASSY NUMBER:							
ITEM	PART NO	DESCRIPTION	QTY	ITEM	PART NO	DESCRIPTION	QTY
1	200243 01	FINGER STIFFENER	54				

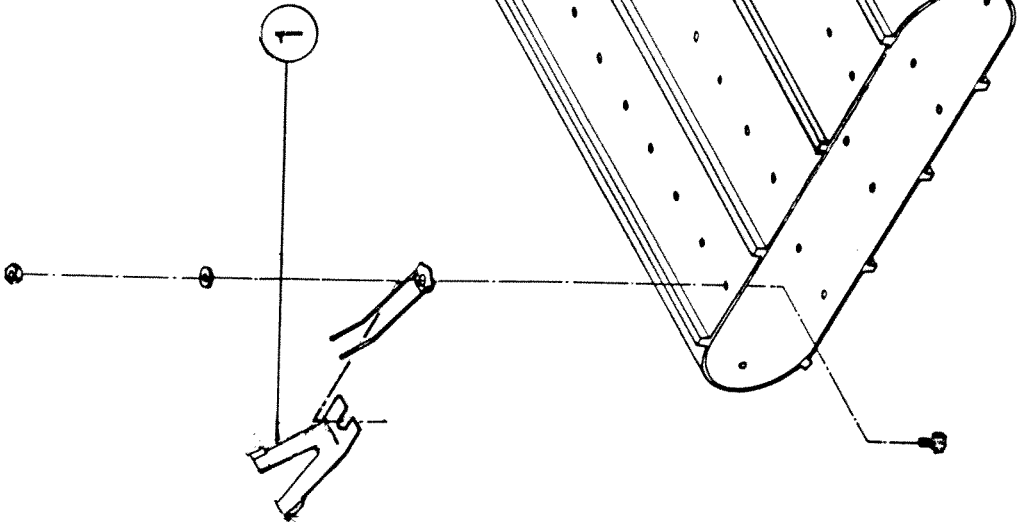

ARRANGE ITEM 1 AS ILLUSTRATED BELOW:

PLASTIC TINE ONLY

PLASTIC TINE WITH FINGER
STIFFENER (ITEM 1).

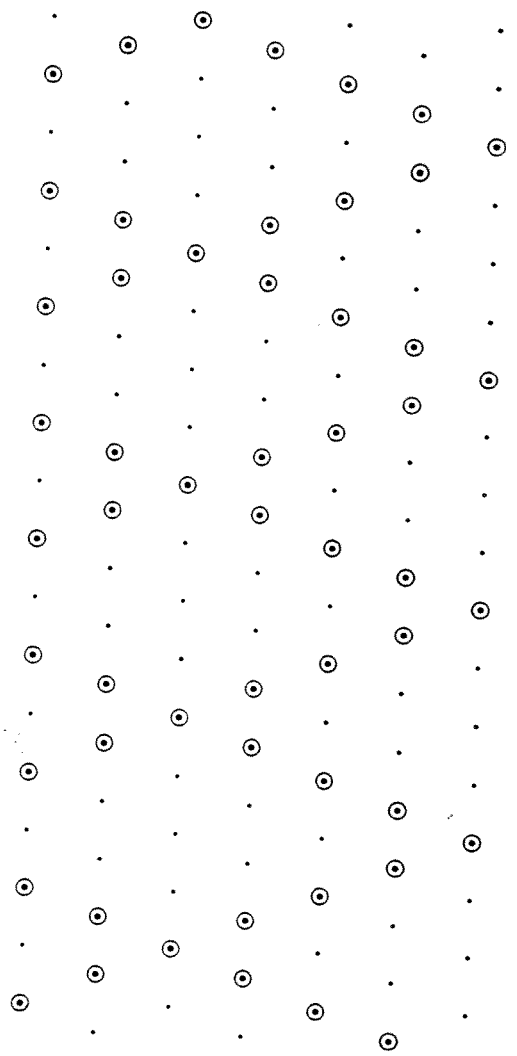

Shelbourne Reynolds Engineering Limited

KIT-02512		ASSY DESCRIPTION: HYD.CIRCUIT FITTINGS (REV)					
ASSY NUMBER:	KIT-02512	ASSY DESCRIPTION: HYD.CIRCUIT FITTINGS (REV)					
ITEM	PART NO	DESCRIPTION	QTY	ITEM	PART NO	DESCRIPTION	QTY
1	ONUT00035	NUT	2				
2	FITB00135	OLIVE	2				
3	200172 01	NON RETURN VALVE	2				
4	WSH-1030	DOWTY WASHER	2				
5	200170 01	HYDRAULIC TEE	2				
6	WSH-1020	DOWTY WASHER	11				
7	HMA-0074	FITTING	4				
8	HVB-20510	NON RETURN VALVE	2				
9	HACAA1111	FITTING	2				
10	200171 01	MANIFOLD	1				
11	FITC00311	BLANKING PLUG	1				
12	HPTJ01011	FITTING	2				
13	ONUT00022	NUT	2				
14	FITB00122	OLIVE	2				
15	HHAH02220	HYDRAULIC HOSE ASSY	1				
16	WSH-1025	DOWTY WASHER	2				
17	FIT-0546	FITTING	2				

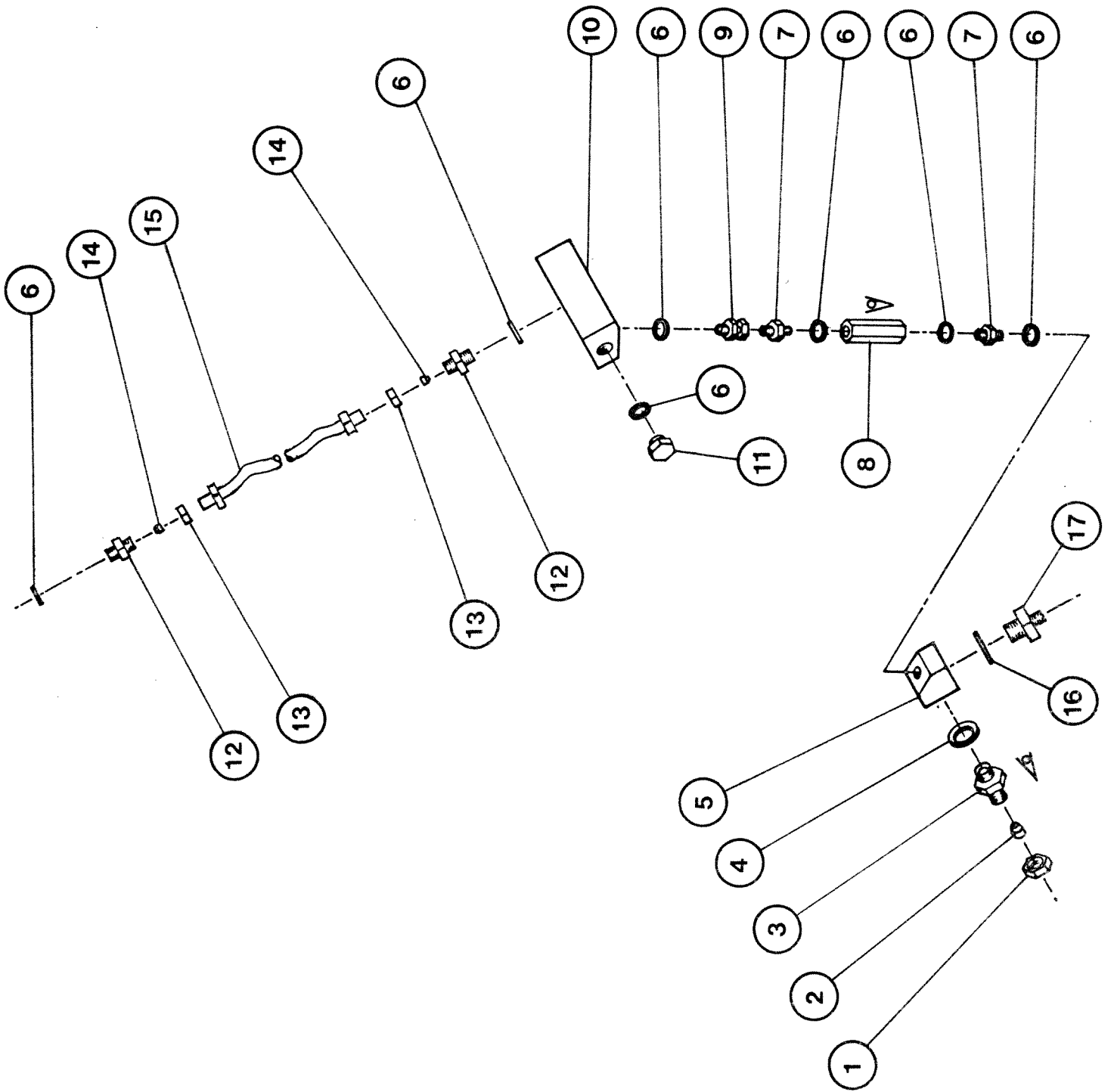

NUMERIC PARTS LIST

PART No.	PAGE	PART No.	PAGE	PART No.	PAGE
108303 04	54	200113 01	50	FIT-0251	64
108304 04	54	200114 01	50	FIT-0546	64
108310 01	42	200120 01	52		72
109005 01	54	200121 01	50	FIT-0548	64
109006	56	200124 01	46	FITC00311	72
109007	56	200128 01	60	GAU-0010	60
127075 12	68	200136 01	42	HACAA1111	72
132001 01	50	200137 03	42	HCPD01800	64
132010 01	50	200139 01	42	HFAI14013	64
132011	50	200146 01	42	HHAH02220	72
132012	50	200170 01	72	HHDF09305	64
132013	50	200171 01	72	HHDF14705	64
132019 01	50	200172 01	72	HMA-0067	64
134024 05	68	200196 01	40	HMA-0074	64
190119 04	42	200197 01	62		72
	46	200198 01	66	HOS-1030	64
	52	200243 01	70	HOS-1050	60
190585 04	52	200250 01	66		60
190585 06	52	200257 01	66		60
190702 04	68	200258 01	58		60
191981 01	68	200281 01	50		60
193390 01	68	200281 02	50		60
193391 01	68	200289 01	58		60
193393 01	68	200291 01	68	HPTJ01011	72
200000 01	42	209000 03	42	HSS-0086	54
200000 02	42	209002 01	46		64
200007 01	42	209004 01	52	HSS-0125	58
200010 01	54	209011 01	64	HSS-0135	46
200019 01	42	590000 01	68	HSS-0140	50
200028 01	44	610250 01	68	HSS-0145	56
200030 01	46	610257 01	68	HSS-0188	42
	58	ADL-00125	42	HSS-0191	56
200031 01	46	BLT-3812	52		58
200031 02	46	BLT-4710	58	HSS-0194	42
200032 01	50	BLTA10350	50	HSS-0198	42
200034 01	52	BLTA12290	46	HSS-0238	60
200038 01	52	BRG-0218	50	HSS-0241	42
200040 01	48	BRG-7050	42		52
200043 01	52	BRG-7060	42	HSS-0250	42
200078 01	54	BRG-7080	50	HSS-0314	58
200079 01	54	BRG-7090	52	HVB-19000	62
200080 01	54	BRT-0005	60	HVB-20510	72
200083 01	56	BSH-1530	44	HVB-22035	64
200084 01	56		48	K0606030	50
200086 01	58	CIR-0050	52	K0807060	50
200086 02	58	CIR-4020	42	KIT-02512	64
200087 01	58	CLP-0070	64	MOTH08000	44
200102 01	42	CLP-0120	60	MOTH16041	48
200105 01	42	FIL-0110	64	NUT-0167	42
200107 01	42	FIT-0080	64	NUT-0170	52

NUMERIC PARTS LIST

PART No.	PAGE	PART No.	PAGE	PART No.	PAGE
NUT-0215 40	WSH-0058 46		
NUT-0260 50	 50		
 54	WSH-0061 42		
NUT-0263 50	WSH-0065 46		
 56	WSH-0070 58		
 58	WSH-0110 40		
NUT-0265 42	WSH-1010 64		
 50	WSH-1015 64		
 56	WSH-1020 64		
 58	 72		
 64	WSH-1025 64		
NUT-0269 42	 72		
 52				
 60				
NUT-0270 44				
 48				
NUT-0370 54				
PIN-1167 50				
PIN-1170 56				
PIN-4511 54				
POP-0006 68				
SCBA08172 50				
SCCA10592 64				
SCW-0516 42				
SCW-0518 60				
SCW-0519 44				
 48				
SCW-0525 54				
SCW-1730 46				
SCW-1955 52				
SCW-4540 52				
SCW-4960 50				
SCW-6000 40				
TIN-0020 40				
WSH-0009 50				
 54				
WSH-0012 50				
 56				
 58				
WSH-0015 42				
 56				
 58				
 64				
WSH-0018 44				
 48				
 52				
 60				
WSH-0024 58				
WSH-0056 50				
 64				

